

WALLS

the ABC
of wall
decoration

ORAC[®]
DECOR



ORAC®
D E C O R

GIVE WALLS *PERSONALITY*

2

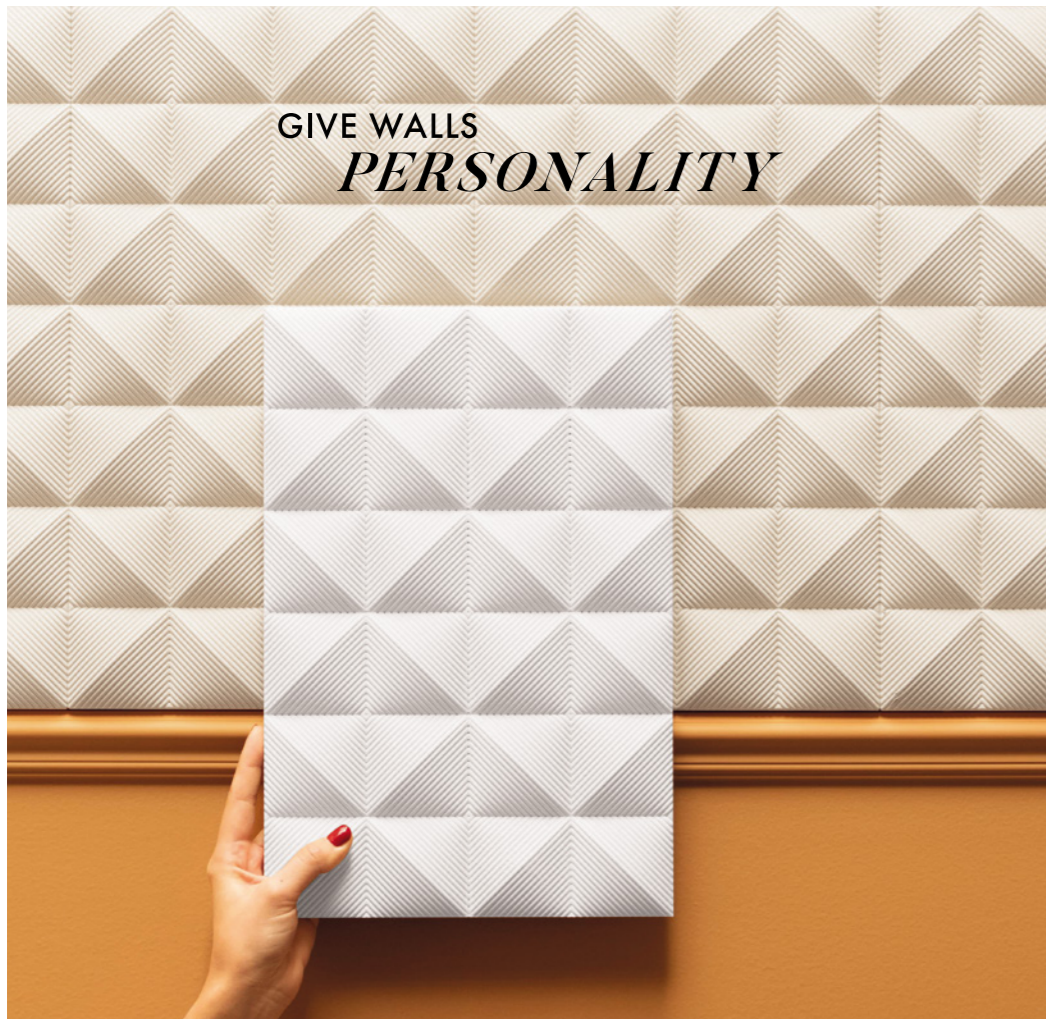

en —

Walls have power. They can be invisible, but they can be so much more. Walls tie a room together or divide it. They determine the mood of a space, whether serenity, grandeur, homeliness or festivity.

We believe walls are the most important element of an interior. And that's why we're so passionate about them. Orac Decor® builds on 50 years of history, innovation and quality to revive heritage and create the walls of the future. Let us share our passion with you.

fr —

Les murs ont de l'énergie. Ils peuvent être invisibles, mais ils peuvent être bien plus. Les murs peuvent relier une pièce ou la diviser. Ils peuvent déterminer l'ambiance d'un espace, qu'il s'agisse de sérénité, de grandeur, de convivialité ou de festività.

Nous pensons que les murs sont l'élément le plus important d'un intérieur. C'est pourquoi ils nous passionnent. Orac Decor® s'appuie sur 50 ans d'histoire, d'innovation et de qualité pour revitaliser l'héritage ancien et créer les murs de l'avenir. Laissez-nous partager notre passion avec vous.

es —

Las paredes tienen un poder enorme. Para algunos son invisibles, pero para nosotros son mucho más. Las paredes pueden unir una habitación o dividirla. Pueden determinar el estado de ánimo de un espacio. Tienen el poder de convertirlo en un rincón sereno, un hogar, algo especial o el escenario de una celebración.

Creemos que las paredes son el elemento más importante de un interior. Y por eso nos apasionan tanto. Orac Decor® tiene a sus espaldas más de 50 años de historia, innovación y calidad para revivir el legado antiguo y crear las paredes del futuro. ¡Apasíonate por este mundo!

nl —

Muren zijn machtig. Ze kunnen onzichtbaar zijn, maar ook zoveel meer. Muren kunnen een ruimte samenbrengen of ze verdelen. Ze kunnen de uitstraling van een ruimte bepalen, van sereniteit of grandeur tot gezelligheid of uitbundigheid.

Voor ons zijn de muren het element bij uitstek van een interieur. Vandaar dat we er zo gepassioneerd mee begaan zijn. Orac Decor® bouwt op 50 jaar geschiedenis, innovatie en kwaliteit om tradities heruit te vinden en om de muren van de toekomst te creëren. We delen graag onze passie met jou.

de —

Wände haben Macht. Sie können unauffällig sein, aber auch noch so viel mehr. Wände können einen Raum optisch zusammenhalten oder ihn unterteilen. Ob ruhig, prunkvoll, gemütlich oder festlich: Wände können die Stimmung eines Raumes prägen.

Wir glauben, dass Wände das wichtigste Element eines Innenraums sind. Deshalb lassen wir uns jeden Tag aufs Neue von Wänden begeistern. Orac Decor® baut auf 50 Jahre Unternehmensgeschichte, Innovation und Qualität auf, um Traditionelles wiederzubeleben und die Wände der Zukunft zu schaffen. Lassen Sie sich von unserer Begeisterung anstecken.

it —

Le pareti sono molto importanti. Possono essere invisibili, ma possono essere molto di più. Le pareti possono collegare le stanze tra di loro o dividerle. Possono determinare l'atmosfera di un ambiente: serena, maestosa, familiare o festosa.

Riteniamo che le pareti siano l'elemento più importante di un interno. Ed è per questo motivo che sono al centro della nostra attenzione. Orac Decor® si basa su 50 anni di storia, innovazione e qualità per far rivivere le tradizioni e gli stili del passato e creare le pareti del futuro. Condividiamo con voi la nostra passione.

3

en

05	The wall says it all
16	Projects
30	Materials
32	Product Overview
34	Cornices
52	Skirting Boards
62	Panel Mouldings
70	3D Wall Covering
78	Led Coving
84	Deco Elements
92	The Perfect Finish
94	Flexible products

nl

05	The wall says it all
16	Projecten
30	Materialen
32	Productoverzicht
34	Kroonlijsten
52	Plinten
62	Wandlijsten
70	3D Wandbekleding
78	Indirecte Verlichting
84	Decoratieve Elementen
92	De Perfecte Afwerking
94	Flexibele Producten

fr

05	The wall says it all
16	Projets
30	Matériaux
32	Aperçu Produits
34	Corniches
54	Plinthes
62	Cimaises
70	Revêtements muraux 3D
78	Eclairage Indirect
84	Éléments Décoratifs
92	La Finition Parfaite
94	Produits Flexibles

de

05	The wall says it all
16	Projekte
30	Materialien
32	Produktübersicht
34	Stuckleisten
52	Sockelleisten
62	Wand- und Friesleisten
70	3D Wandvertäfelung
78	Indirekte Beleuchtung
84	Zierelemente
92	Die perfekte Installation
94	Biegbare Produkte

es

05	The wall says it all
16	Proyectos
30	Materiales
32	Resumen de Productos
34	Cornisas
54	Zócalos
62	Molduras
70	Revestimiento de pared 3D
78	Iluminación Indirecta
84	Elementos de Decoración
92	El Acabado Perfecto
94	Productos Flexibles

it

05	The wall says it all
16	Progetti
30	Materiali
32	Sommario Prodotti
34	Cornici Soffitto
52	Battiscopa
62	Cornici Parete
70	Rivestimento murale 3D
78	Illuminazione Indiretta
84	Elementi Decorativi
92	La Finitura Perfetta
94	Profili Flessibili

The wall says it all

Explore our House of Personality.

Let your creativity take over as you move from bedroom to bathroom and from kitchen to living room. Imagine injecting your personality on the walls. What will inspire you today?

nl

Ontdek ons House of Personality. Laat je creativiteit de vrije loop terwijl je van de slaapkamer naar de badkamer gaat en van de keuken naar de woonkamer. Beeld je in dat je de wanden aankleedt met jouw persoonlijkheid. Wat inspireert jou vandaag?

fr

Explorez notre maison des personnalités. Laissez libre cours à votre créativité lorsque vous passez de la chambre à coucher à la salle de bains et de la cuisine au salon. Imaginez que vous projetiez votre personnalité sur les murs. Qu'est-ce qui vous inspirera aujourd'hui ?

de

Entdecken Sie unser Haus der Persönlichkeit. Lassen Sie Ihrer Kreativität freien Lauf, wenn Sie vom Schlafzimmer ins Bad und von der Küche ins Wohnzimmer spazieren. Stellen Sie sich vor, dass Sie den Wänden Ihre Persönlichkeit verleihen. Was inspiriert Sie heute?



es

Descubre y déjate seducir por House of Personality. Dale rienda suelta a tu creatividad mientras recorres las secciones dedicadas a dormitorios, cuartos de baño, cocinas y salones que tenemos preparadas para ti. ¿Te imaginas poder reflejar tu personalidad en las paredes de tu vivienda? ¿Con qué te seduciremos hoy?

it

Esplora la nostra Casa della Personalità. Lascia che la tua creatività prenda il sopravvento mentre ti sposti dalla camera da letto al bagno e dalla cucina al soggiorno. Immagina di trasferire la tua personalità nelle pareti. Cosa ti ispirerà oggi?



Wall structure and surface textures are combined to create this **relaxing living room**.

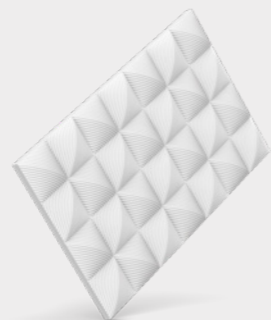

3 W113 COBBLE



1 SX195 HAMBURG

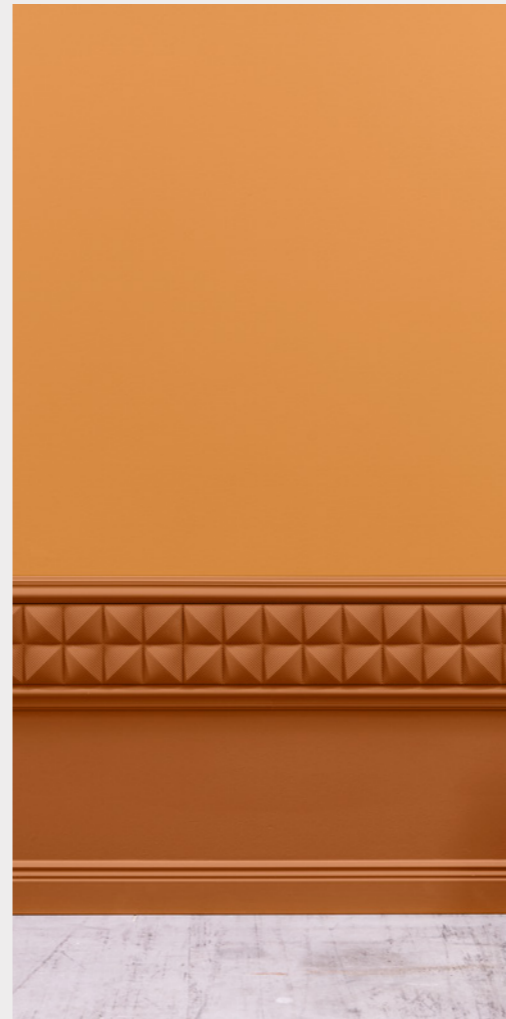

nl —

Gestructureerde wanden en textuurvlakken worden gecombineerd in deze gezellige leefruimte.

fr —

La structure du mur et les textures de surface sont combinées pour créer ce salon relaxant.

de —

In diesem Wohnzimmer werden Wandstruktur und Oberflächentextur miteinander kombiniert, um eine entspannte Atmosphäre zu schaffen.

es —

La estructura de la pared y las texturas de la superficie se combinan para crear este relajante salón.

it —

La struttura delle pareti e le texture delle superfici si combinano per dar vita a questo salotto rilassante.



Strong patterns and graphic lines transform a dull passage into an **eye-catching entrance.**



1. SX194 p.67 | 2. SX184 p.67 | 3. C373 p.83 | 4. W113 p.73

nl —

Krachtige patronen en grafische lijnen toveren een donkere, saaie ruimte meteen om tot een oogverblindende hal.

fr —

Des motifs et des lignes graphiques puissants transforment immédiatement un espace sombre et ennuyeux en couloir attirant.

de —

Markante Muster und grafische Linien verwandeln einen dunklen und langweiligen Raum sofort in einen Flur, der sofort zu einem Blickfang wird.

es —

Patrones y líneas gráficas potentes capaces de transformar en cuestión de segundos un espacio oscuro y aburrido en un atractivo pasillo.

it —

Motivi e linee grafiche forti trasformano immediatamente uno spazio buio e monotono in un corridoio bello e appariscente.

Unconventional combinations in our cosmopolitan kitchen bring daily inspiration.

10

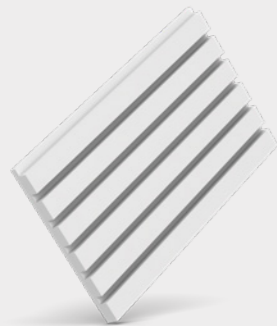

5 W111 BAR



1 SX193 AUTOIRE



1. SX193 p.52 | 2. W120 p.76 | 3.W121 p.76 | 4. C324 p.78 | 5. W111 p.72 | 6. SX194 p.49

nl —

De buitengewone combinaties in onze wereldse keuken inspireren elke dag.

fr —

Les combinaisons non conventionnelles dans notre cuisine cosmopolite sont une source d'inspiration quotidienne.

de —

Die unkonventionellen Kombinationen in unserer kosmopolitischen Küche inspirieren uns jeden Tag aufs Neue.

es —

Las combinaciones poco convencionales de nuestra cocina cosmopolita son una fuente diaria de inspiración.

it —

Le combinazioni inconsuete della nostra cucina cosmopolita sono una fonte d'ispirazione quotidiana.

11

Kitchen

Linear, curved or ornamented. The variety of shapes in this eclectic reading room energise me to express myself.

12



1. W110 p.70 | 2. W108 p.70 | 3. W112 p.73 | 4. W130 p.72 | 5. W109 p.70 | 6. W111 p.72 | 7. W113 p.73 | 8. CX190 p.82

nl —

Rechtlijnig, gebogen of geornamenteerd. De vormen in deze eclectische leesruimte geven me energie om mezelf uit te drukken.

fr —

Linéaire, courbée ou décorée. Les formes de cette salle de lecture éclectique me donnent énergie et créativité.

de —

Geradlinig, geschwungen oder ornamentiert. Die Formen in diesem vielseitigen Lesezimmer regen mich dazu an, meine Persönlichkeit auszudrücken.

es —

Lineal, curvada u ornamentada. Las formas de esta sala de lectura ecléctica animan a la expresión.

it —

Lineari, curve o ornate. Le forme di questa stanza eclettica mi stimolano a esprimermi.

13

Reading room

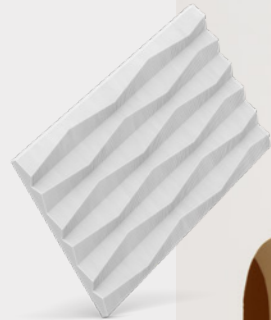

2 W112 RIDGE



nl —

Welkom in mijn stadse zakenpaleis waar subtiële rechthoekige herhalingen een gestructureerd en georganiseerd resultaat geven.

fr —

Bienvenue dans mon palais des affaires urbaines où des répétitions linéaires subtiles créent un résultat structuré et organisé.

de —

Willkommen in meinem urbanen Arbeitspalast, in dem die dezente Wiederholung der Linienführungen für einen strukturierten Gesamteindruck sorgt.

es —

Bienvenido a nuestro palacio empresarial urbano, un espacio donde las sutiles repeticiones lineales logran un resultado estructurado y organizado.

it —

Benvenuti nel mio ufficio, dove delicate ripetizioni lineari danno un effetto strutturato e organizzato all'ambiente.

Welcome to my
urban business
environment
where linear
repetition creates
a structured and
organized finish.



1. SX157 p.57 | 2. W112 p.73 | 3. SX194 p.67

For the love of walls

Inspiring projects bursting with personality

16



1. SX168 p.57 | 2. SX162 p.67

PILLOWS HOTEL — GENT (BE)

BOULANGERIE HENRI — KNOKKE (BE)



3. P3020 p.64 | 4. P3020A p.69 | 5. P8040 p.63 | 6. SX118 p.58 | 7. P8020 p.62 | 8. P8030 p.62 | 9. C343 p.34

ORAC
DECOR

17



Projects

GIVE WALLS
PERSONALITY

MODERN



18

CLASSIC

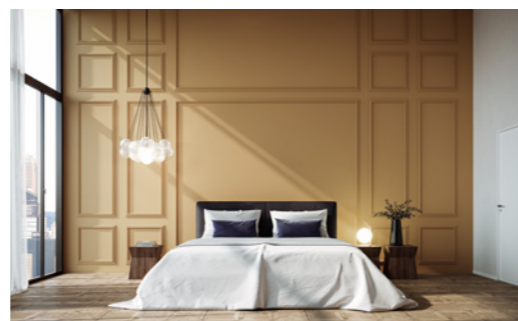

ECLECTIC



ZEN

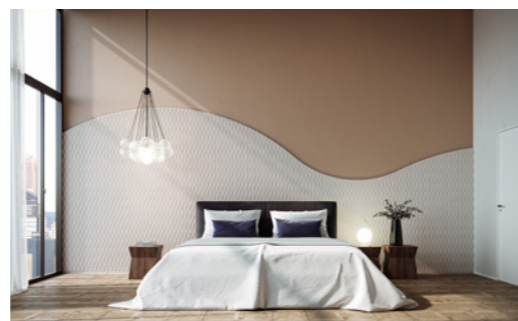

Well-dressed windows.

Use our curtain profiles to hide your curtain rails in an instant for non-stop elegance.

nl —

Goed geklede ramen. Gebruik onze gordijnprofielen om je gordijnrails te verbergen voor onmiddellijke elegantie.

fr —

Des fenêtres bien habillées. Utilisez nos profils de rideaux pour cacher vos tringles afin d'obtenir une élégance instantanée.

de —

Gut gekleidete Fenster. Mit unseren Gardinenleisten verbergen Sie geschickt und auf elegante Weise störende Vorhangschienen.

es —

Ventanas bien vestidas. El diseño de nuestras cortinas le ayudará a ocultar los rieles y obtener una elegancia instantánea.

it —

Finestre ben curate. Usa i nostri profili per tende per nascondere le guide per tende, per un'eleganza immediata.



1. SX162 p.57 | 2. C396 p.45 | 3. C342 p.34

19

Projects

GIVE WALLS *PERSONALITY*

CLASSIC



20

MODERN



ZEN



ECLECTIC



Composed elegance.

Combine multiple cornice mouldings to create a beautiful transition from wall to ceiling.



nl —

Verfijnd veelvoud. Combineer verschillende kroon- en wandlijsten om een unieke overgang tussen wand en plafond te creëren.

fr —

Une élégance composée. Combinez plusieurs corniches et profils pour créer un effet de transition unique entre le mur et le plafond.



1. SX156 p.53 | 2. P8030 p.62 | 3. P8020 p.62 | 4. DX170-2300 p.88 | 5. C362 p.83 | 6. P9901 p.65 | 7. C342 p.34 | 8. P8050 p.62

de —

Harmonische Eleganz. Kombinieren Sie mehrere Stuck- und Wandleisten, um den Übergang von der Wand zur Decke einzigartig wirken zu lassen.

es —

Elegancia compuesta. Combine varias cornisas y perfiles para lograr una transición perfecta de la pared al techo.

it —

Eleganza discreta. Associa diverse modanature di cornici e profili per creare un effetto di transizione unico dalla parete al soffitto.

21

Projects

GIVE WALLS *PERSONALITY*

CLASSIC



ECLECTIC



MODERN



ZEN



1. PX102 p.67 | 2. PX175 p.66

nl —
Muren verdienen persoonlijkheid.

de —
Wände verdienen Persönlichkeit.

Walls deserve personality

fr —
Les murs méritent une vraie personnalité.

es —
Tus paredes también merecen derrochar personalidad.

it —
Le pareti devono esprimere personalità.

Before ...



24

Highlight the ceiling.

Use led coving for a more spacious effect.

fr —

Faites ressortir le plafond. Utilisez un éclairage indirect pour un effet plus spacieux.

nl —

Licht het plafond uit. Gebruik indirecte verlichting voor een verruimend effect.

de —

Rücken Sie die Decke ins rechte Licht. Erhöhen Sie optisch den Raum mit einer indirekten Beleuchtung und schaffen Sie mehr Räumlichkeit.

& after



1. SX156 p.53 | 2. P8030 p.62 | 3. C901 p.79

es —

Resalta el techo. Opta por la luz indirecta para hacer que tu salón parezca más espacioso.

it —

Metti in evidenza il soffitto. Utilizza l'illuminazione indiretta per un effetto di maggiore spazio.

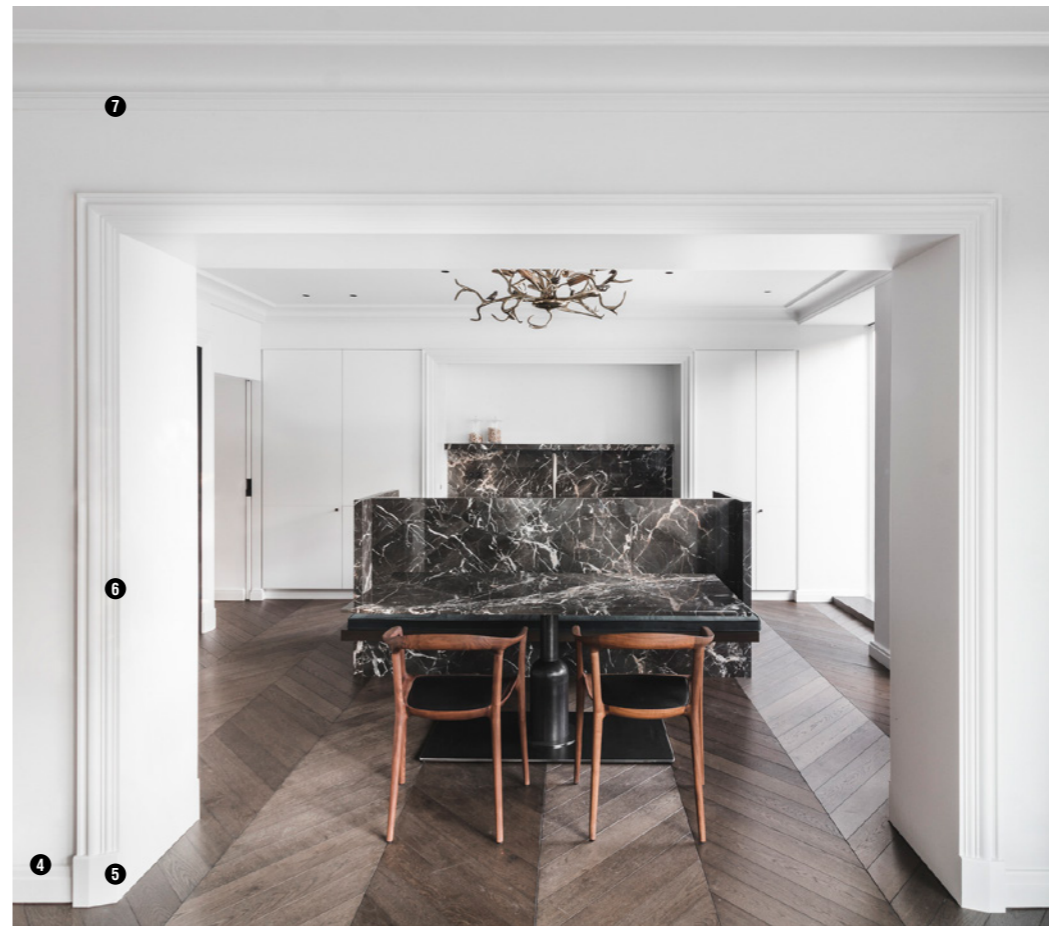

4. SX155 p.54 | 5. D330LR p.88 | 6. DX170-2300 p.88 | 7. C342 p.34



25

Projects

Before ...



& after



1. SX138 p.52 | 2. W121 p.76 | 3. W120 p.76 | 4. C324 p.78 | 5. C344 p.34 | 6. P4025 p.63

Walls are not supposed to be boring



7. SX163 p.57 | 8. P8030 p.62 | 9. C343 p.34



nl —
Muren zijn niet gemaakt om saai te blijven.

fr —
Les murs ne sont pas faits pour être ennuyeux.

de —
Wände sind nicht dazu da, langweilig zu sein.

es —
Las paredes no están hechas para ser aburridas.

it —
Le pareti non sono fatte per essere noiose.

Instant replay.
Install profiles in repetitive sequences to give your hall depth and structure.

nl —
Instant herhaling. Plaats de profielen in een repetitief patroon om je hal diepte en structuur te geven.

fr —
Répétition instantanée. Utilisez les profilés dans une séquence répétitive pour donner une profondeur et une structure immédiates à votre couloir.

de —
Gleich noch einmal. Verwenden Sie Profile in sich wiederholenden Sequenzen, um Ihrem Flur sofort Tiefe und Struktur zu verleihen.

es —
Reproducción instantánea. Utilice perfiles en una secuencia repetitiva para dar a su pasillo una profundidad y estructura instantáneas.

it —
Replay istantaneo. Utilizza i profili in sequenza ripetuta per donare al tuo corridoio un effetto immediato di struttura e profondità.

Bring your walls



1. SX118 p.58 | 2. PX103 p.66 | 3. C343 p.34

nl —

Laat je muren tot leven komen.

fr —

Donnez vie à vos murs.

de —

Erwecken Sie Wände zum Leben.

es —

Dale vida a tus paredes.

it —

Dai nuova vita alle tue pareti.



4. W109 p.70 | 5. W109F p.70 | 6. SX105 p.54 | 7. P7070 p.65 | 8. SX187 p.54



nl —

Elke muur is een uitnodiging om iets moois te creëren.

de —

Jede Wand ist eine Einladung, um etwas Schönes zu schaffen.

fr —

Chaque mur est une invitation à créer de la beauté.

es —

Cada pared es una invitación para crear belleza.

it —

Ogni parete è un invito a creare bellezza.

Every wall is an invitation to create beauty



to life

Engineered Materials

INGENIEUZE MATERIALEN / MATÉRIAUX TECHNIQUES
DURCHDACHTE MATERIALEN / MATERIALES DE INGENIERÍA
MATERIALI INGEGNERIZZATI

PUROTOUCH®

A high-quality, high-density polyurethane that allows fine details.

Een kwalitatieve polyurethaan van hoge dichtheid die scherpe details mogelijk maakt.

Un polyuréthane de qualité à haute densité qui permet de créer des détails fins.

Ein qualitativ hochwertiges Polyurethan hoher Dichte, das schöne Details möglich macht.

Un poliuretano de alta densidad y calidad con el que crear pequeños detalles.

Poliuretano di alta qualità e alta densità che consente dettagli ben definiti.

Detail Design ★★ ★

Impact Resistance ★★

DUROPOLYMER®

An extruded and impact-resistant polymer based on a high-density polystyrene.

Geëxtrudeerde en impactbestendige polystyreenmix van hoge dichtheid.

Un polymère extrudé résistant aux impacts à base d'un mélange de polystyrènes haute densité.

Extrudierter und schlagfester, hochdichter Polystyrol-Mix.

Polímero fabricado por extrusión, resistente a impactos fuertes a base de una mezcla de poliestireno de alta densidad.

Polimero estruso resistente agli urti, formato da una miscela di polistirene ad alta densità.

Detail Design ★★

Impact Resistance ★★ ★

DUROFOAM®

An extruded lightweight polymer based on a medium-density polystyrene blend.

Geëxtrudeerde lichtgewicht polystyreenmix van medium dichtheid.

Un polymère léger extrudé à base d'un mélange de polystyrènes de densité moyenne.

Extrudiertes, leichtes Polymer auf der Grundlage eines Polystyrol-Mix mittlerer Dichte.

Polímero extrusionado de peso ligero a base de una mezcla de poliestireno de densidad media.

Polimero leggero estruso, formato da una miscela di polistirene di media densità.

Detail Design ★

Impact Resistance ★

Advantages

VOORDELEN / AVANTAGES / VORTEILE / VENTAJAS / VANTAGGI

READY TO PAINT

All of our products are ready to paint. RAL-colours on demand.

Al onze producten worden schilderklaar geleverd. RAL-kleuren op aanvraag.

Tous nos produits sont prêts à peindre. Couleurs RAL sur demande.

Alle unsere Produkte sind bereit zum Beschichten. RAL-Farben auf Anfrage.

Todos nuestros productos están listos para ser pintados. Colores RAL bajo demanda.

Tutti i nostri prodotti sono pronti per essere verniciati. Colori RAL su richiesta.



DURABLE

Orac Decor® products are designed to last a lifetime. Smart design and high-end technology assure strong and water resistant products.

Orac Decor® producten zijn ontwikkeld om een leven lang mee te gaan. Slim productdesign en state-of-the-art technologie verzekeren sterke en waterbestendige producten.

Les produits Orac Decor® sont conçus pour durer toute une vie. Une conception intelligente et une technologie haut de gamme garantissent des produits robustes et résistants à l'eau.

Orac Decor®-Produkte halten ein Leben lang. Intelligentes Design und hochwertige Technologie sorgen für robuste und absolut wasserbeständige Produkte.

Los productos de Orac Decor® están diseñados para durar toda la vida. Gracias a su diseño inteligente y la tecnología de vanguardia, se trata de productos sólidos y resistentes al agua.

I prodotti Orac Decor® sono progettati per durare tutta la vita. Il design intelligente e la tecnologia di alta gamma garantiscono prodotti robusti e resistenti all'acqua.



Product Overview



32



Cornice Mouldings

Kroonlijsten / Corniches / Eckleisten / Cornisas
Cornici Soffitto

Pg. 34



Skirting Boards

Plinten / Plinthes / Sockelleisten / Zócalos
Battiscopa

Pg. 52

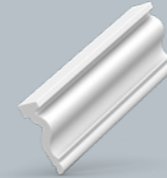

Panel Mouldings

Wandlijsten / Cimaises
Wand- und Friesleisten / Molduras / Cornici Parete

Pg. 62



3D Wall Covering

3D Wandbekleding / Revêtements muraux 3D
3D Wandvertäfelung / Revestimiento de pared 3D
Rivestimento murale 3D

Pg. 70

33



Led Coving

Indirecte Verlichting / Éclairage Indirect
Indirekte Beleuchtung / Iluminación Indirecta
Illuminazione Indiretta

Pg. 78



Deco Elements

Decoratieve Elementen / Éléments Décoratifs
Zierelemente / Elementos de Decoración
Elementi Decorativi

Pg. 84

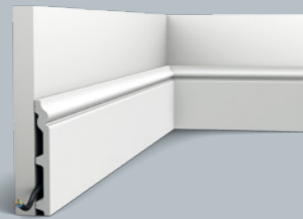

LEGEND

SX118 | SX118F | SX118 - RAL9003 — **RAL 9003** = Finished with RAL9003 (white, on stock)
200 x 13,8 x 1,8 cm — Dimensions
Duropolymer® — Material

F = Flexible polyurethane version

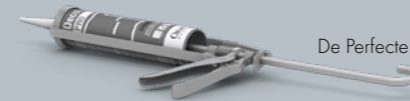

The Perfect Finish

De Perfecte Afwerking / La Finition Parfaite / Die perfekte Installation / El Acabado Perfecto / La Finitura Perfetta

Pg.92

Cornice Mouldings

KROONLIJSTEN / CORNICHES
ECKLEISTEN / CORNISAS / CORNICI
SOFFITTO



C341 | C341F HERITAGE
200 x 8,8 x 12,2 cm
Purotouch®



C342 HERITAGE
200 x 14 x 19 cm
Purotouch®

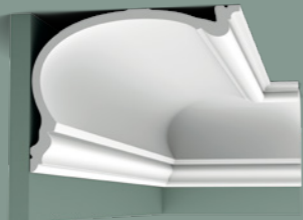

C343 HERITAGE
200 x 19 x 25 cm
Purotouch®

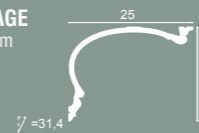

C344 HERITAGE
200 x 27,3 x 35 cm
Purotouch®

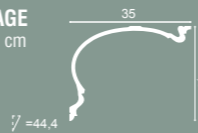

1. SX191 p.53 | 2. P4020 p.62 | 3. P8020 p.62 | 4. C327 p.35



C325 | C325F MANOIR
200 x 7 x 6,5 cm
Purotouch®

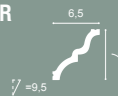

C326 | C326F MANOIR
200 x 10,5 x 9 cm
Purotouch®

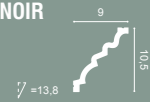

4 C327 MANOIR
200 x 14,3 x 15,9 cm
Purotouch®

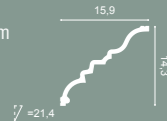

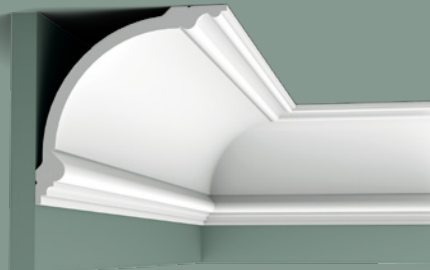

C338 BA'ROCK
200 x 18,2 x 18,2 cm
Purotouch®

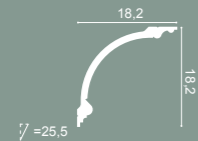

C336 BA'ROCK
200 x 27,1 x 26,6 cm
Purotouch®

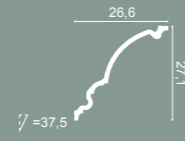

C338B BA'ROCK
200 x 18,2 x 18,2 cm
Dessin: 2 x 57 cm
Purotouch®



C338A BA'ROCK
200 x 18,2 x 18,2 cm
Dessin: 120 cm
Purotouch®

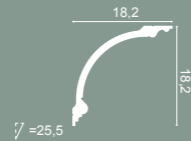

C230 | C230F
200 x 2,9 x 2,9 cm
Purotouch®

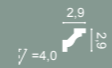

C215 | C215F
200 x 4,7 x 4,7 cm
Purotouch®



C322
200 x 5 x 4,2 cm
Purotouch®



C200
200 x 6,5 x 5,7 cm
Purotouch®

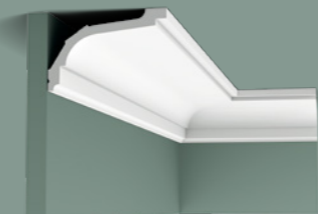

C220 | C220F
200 x 7,6 x 11,6 cm
Purotouch®



C213 | C213F
200 x 8 x 8 cm
Purotouch®

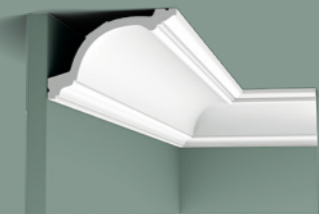
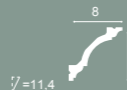

C217 | C217F
200 x 10,3 x 15,6 cm
Purotouch®

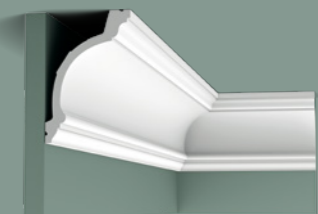

C217 | C217F
200 x 15,6 x 10,3 cm
Purotouch®



C216
200 x 11,6 x 13,3 cm
Purotouch®

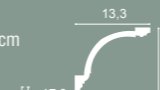

C301
200 x 17 x 14,4 cm
Purotouch®



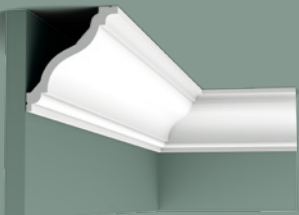

C333 | C333F

200 x 12,2 x 11,1 cm
Purotouch®

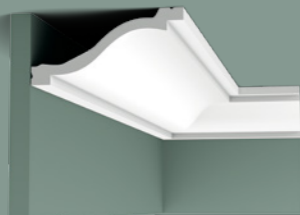
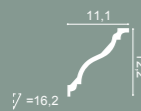

C331 | C331F

200 x 6,4 x 13,5 cm
Purotouch®

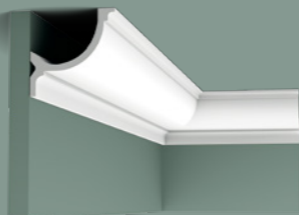

C902 | C902F

200 x 10,3 x 10,3 cm
Purotouch®

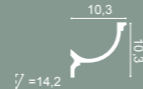

4 C305

200 x 4,7 x 15,5 cm
Purotouch®

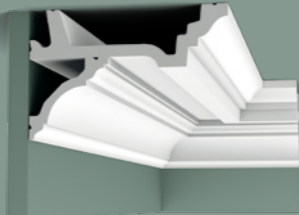

C305 + C213



C305 + C211

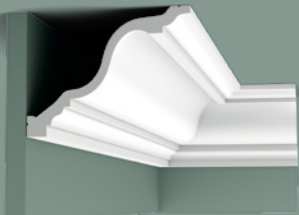
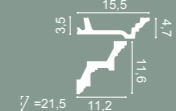

C334 | C334F

200 x 15 x 19,6 cm
Purotouch®

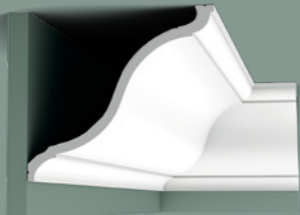
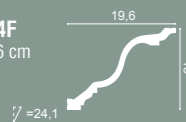

C335

200 x 20,2 x 22,2 cm
Purotouch®
Designed by
Xavier Donck

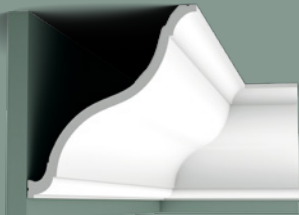
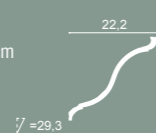

C335

200 x 22,2 x 20,2 cm
Purotouch®
Designed by
Xavier Donck

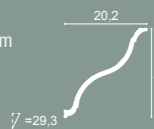

C901 | C901F

200 x 14,8 x 12,4 cm
Purotouch®

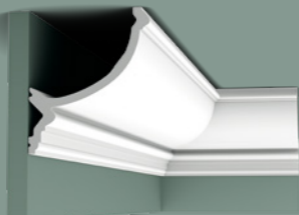

C900

200 x 17,1 x 14,6 cm
Purotouch®

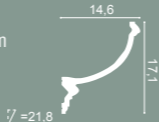

C211 | C211F

200 x 11,6 x 11,2 cm
Purotouch®

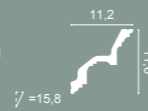

C307

200 x 19,5 x 19,5 cm
Purotouch®



3 C422

200 x 16,4 x 19,4 cm
Purotouch®

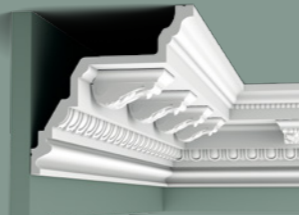
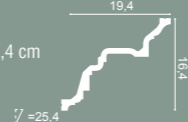

1 C307 + C307A 2

C307A: 7,5 x 4 x 9,4 cm
Duropolymer®

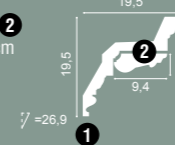

3. C422 p.39 | 3. C305 p.39



C212
200 x 7,5 x 4,5 cm
Purotouch®

4,5
7,5
∇ = 8,5



C201
200 x 11,6 x 4,8 cm
Purotouch®

4,8
11,6
∇ = 12,5



C304 | C304F
200 x 12,2 x 7,2 cm
Purotouch®

7,2
12,2
∇ = 13,9



C303
200 x 14,4 x 6,5 cm
Purotouch®

6,5
14,4
∇ = 15,3



C219
200 x 17,6 x 13 cm
Purotouch®

13
17,6
∇ = 21,8



C308
200 x 24,8 x 6,3 cm
Purotouch®

6,3
24,8
∇ = 25



1. P8020 p.62 | 2. C219 p.40



C321 | C321F
200 x 9,9 x 5 cm
Purotouch®

5
9,9
∇ = 10,8



C339 | C339F
200 x 14,1 x 6,4 cm
Purotouch®

6,4
14,1
∇ = 15,2



C332
200 x 23 x 11,4 cm
Purotouch®

11,4
23
∇ = 25



C332
200 x 11,4 x 23 cm
Purotouch®

23
11,4
∇ = 25



C340
200 x 25,6 x 13,5 cm
Purotouch®

13,5
25,6
∇ = 28,6



C340
200 x 13,5 x 25,6 cm
Purotouch®

25,6
13,5
∇ = 28,6



3. SX156 p.53 | 4. DX170-2300 p.88 | 5. C323 p.78 | 6. C332 p.41



C250 | C250F
200 x 1,6 x 1,6 cm
Purotouch®

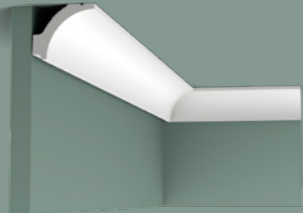

C260
200 x 4,1 x 4,8 cm
Purotouch®



C240 | C240F
200 x 8 x 8 cm
Purotouch®



C991
200 x 11 x 14 cm
Purotouch®
Designed by
Ulf Moritz

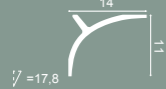

C991 + P9900



C991 + 2x P9900



C991
200 x 14 x 11 cm
Purotouch®
Designed by
Ulf Moritz

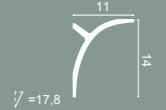

C991 + P9900



C991 + 2x P9900

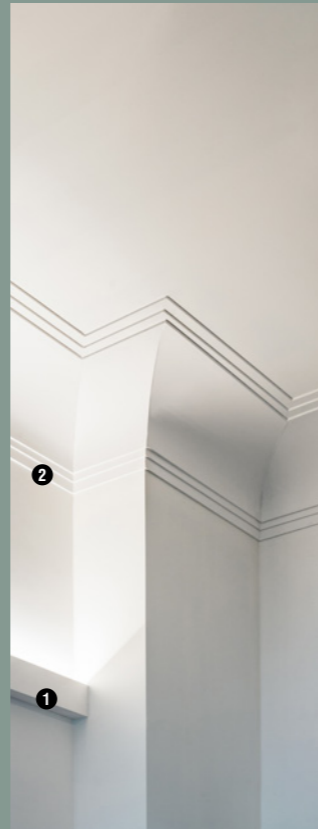

1. C381 p.80 | 2. C990 + 2X P9900 p.43



C990 INFINITY
200 x 15,9 x 21,6 cm
Purotouch®

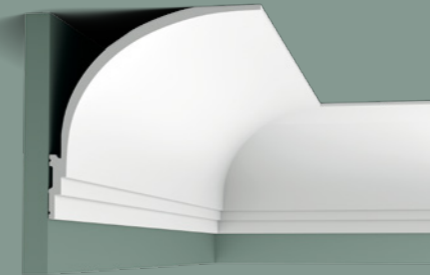

C990 + P9900

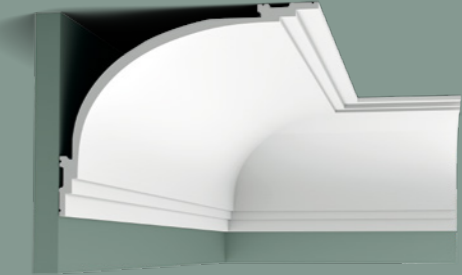

C990 + 2x P9900

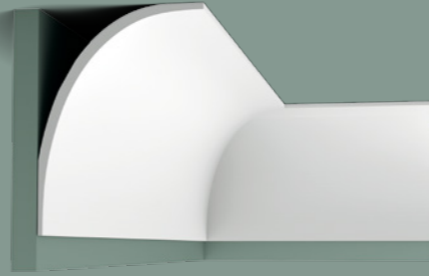

C990 INFINITY
200 x 21,6 x 15,9 cm
Purotouch®

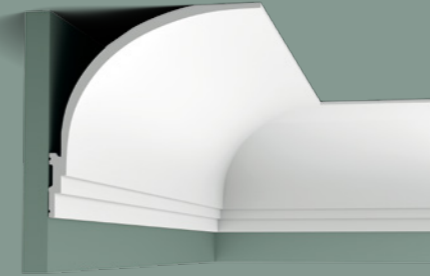
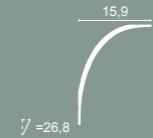

C990 + P9900

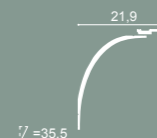

2 C990 + 2x P9900

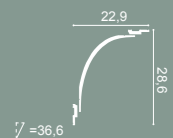

Steps

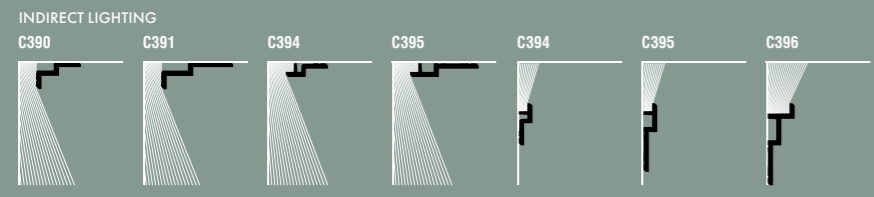
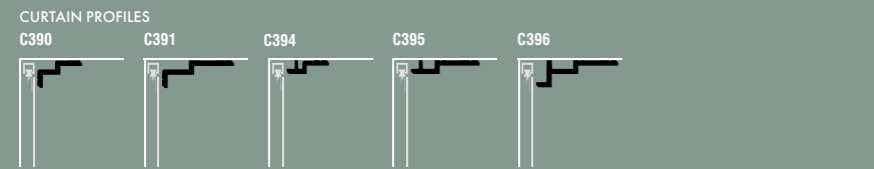
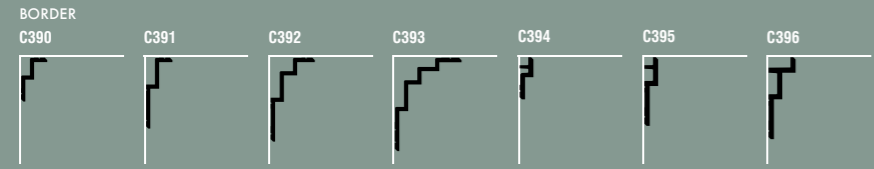
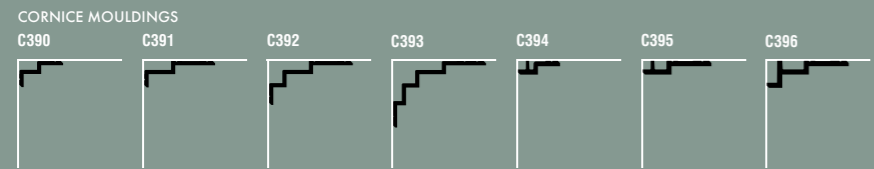

DOWNLIGHTER

UPLIGHTER



1. C393 p.45



C394 STEPS
200 x 9,5 x 3,1 cm
Purotouch®
Designed by Orio Tonini

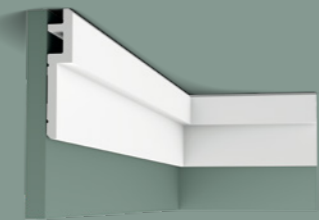
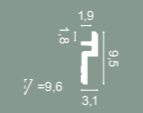

C395 STEPS
200 x 15,5 x 3,1 cm
Purotouch®
Designed by Orio Tonini

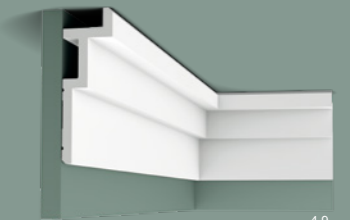

C396 STEPS
200 x 18,5 x 6,1 cm
Purotouch®
Designed by Orio Tonini



C390 STEPS
200 x 6 x 10 cm
Purotouch®
Designed by Orio Tonini

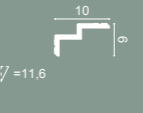

C391 STEPS
200 x 6 x 16 cm
Purotouch®
Designed by Orio Tonini

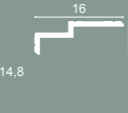

C392 STEPS
200 x 10 x 19 cm
Purotouch®
Designed by Orio Tonini

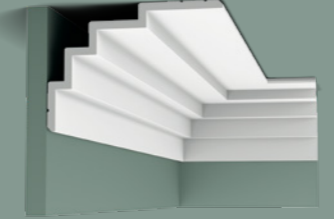
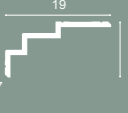

C393 STEPS
200 x 15 x 21 cm
Purotouch®
Designed by Orio Tonini

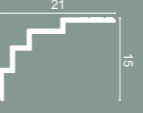



C394 STEPS
CURTAIN PROFILE
200 x 3,1 x 9,5 cm
Purotouch®

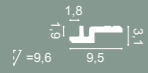

C395 STEPS
CURTAIN PROFILE
200 x 3,1 x 15,5 cm
Purotouch®

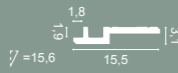

C390 STEPS
CURTAIN PROFILE
200 x 6 x 10 cm
Purotouch®



C391 STEPS
CURTAIN PROFILE
200 x 6 x 16 cm
Purotouch®

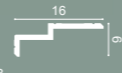

C396 STEPS
CURTAIN PROFILE
200 x 6,1 x 18,5 cm
Purotouch®

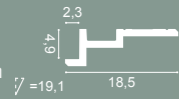

C991
CURTAIN PROFILE
200 x 11 x 14 cm
Purotouch®

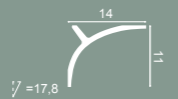

C341 | C341F HERITAGE
CURTAIN PROFILE
200 x 8,8 x 12,2 cm
Purotouch®

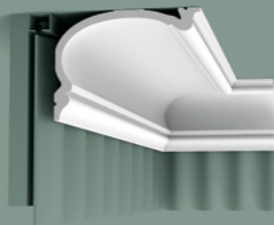

C342 HERITAGE
CURTAIN PROFILE
200 x 14 x 19 cm
Purotouch®

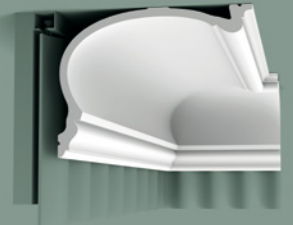

C343 HERITAGE
CURTAIN PROFILE
200 x 19 x 25 cm
Purotouch®



C340
CURTAIN PROFILE
200 x 13,5 x 25,6 cm
Purotouch®



CX196 U-STEPS
200 x 4 x 11,3 cm
Duropolymer®



CX197 U-STEPS
200 x 5 x 9,3 cm
Duropolymer®

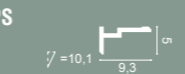

C360
200 x 2,1 x 6 cm
Purotouch®
Designed by Jacques Vergracht



C356
200 x 2 x 10 cm
Purotouch®
Designed by Jacques Vergracht



C355
200 x 3,5 x 11,1 cm
Purotouch®
Designed by Jacques Vergracht



C353
200 x 3 x 16,5 cm
Purotouch®
Designed by Jacques Vergracht



C354
200 x 4 x 21,5 cm
Purotouch®
Designed by Jacques Vergracht



C602
200 x 5,3 x 5 cm
Purotouch®



C400
200 x 6 x 10 cm
Purotouch®



CX124 | CX124F
200 x 4,9 x 4,9 cm
Duropolymer®





CX106 | CX106F
200 x 11,8 x 11,7 cm
Duropolymer®

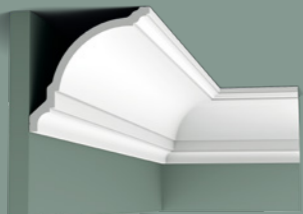
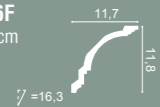

CX203
200 x 14,5 x 14,5 cm
Duropolymer®

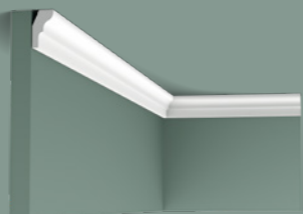
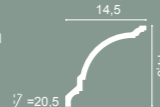

CX111
200 x 2,6 x 1,5 cm
Duropolymer®

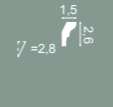

CX154
200 x 3 x 3 cm
Duropolymer®

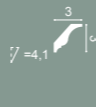

CX133
200 x 2 x 2 cm
Duropolymer®

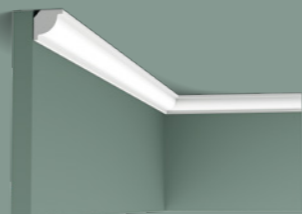
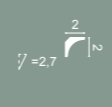

CX132 | CX132F
200 x 2 x 2 cm
Duropolymer®

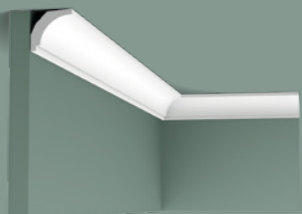
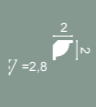

CX115
200 x 3 x 2,9 cm
Duropolymer®

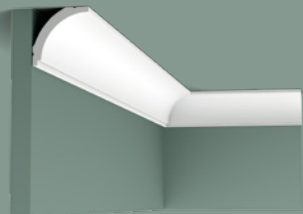

CX109 | CX109F
200 x 4,4 x 4,4 cm
Duropolymer®



CX110 | CX110F
200 x 4,5 x 4,1 cm
Duropolymer®

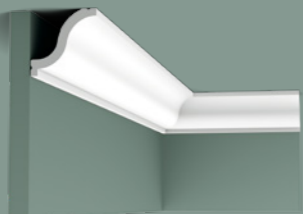

CX108
200 x 5,4 x 5,5 cm
Duropolymer®

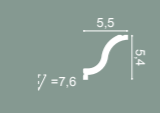

CX112
200 x 5,4 x 3,8 cm
Duropolymer®

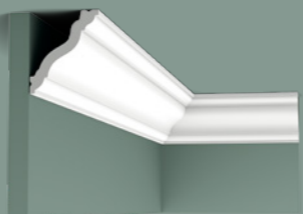

CX177
200 x 7 x 6 cm
Duropolymer®



CX126
200 x 8,7 x 8,7 cm
Duropolymer®

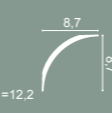

CX148
200 x 4,3 x 2,9 cm
Duropolymer®

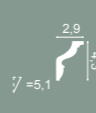

CX141
200 x 5,9 x 3,1 cm
Duropolymer®



CX176
200 x 8 x 4 cm
Duropolymer®



CX101
200 x 6,9 x 7,1 cm
Duropolymer®

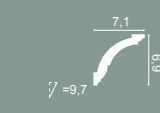

CX129
200 x 9,4 x 9,4 cm
Duropolymer®

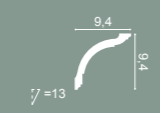

CX128
200 x 9,4 x 9,4 cm
Duropolymer®

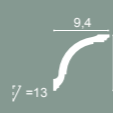

CX107
200 x 11,8 x 11,7 cm
Duropolymer®



CX192
200 x 12 x 6 cm
Duropolymer®

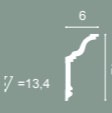

SX194 | SX194F SQUARE
200 x 1 x 2 cm
Duropolymer®



CX190 | CX190F U-PROFILE
200 x 2 x 3 cm
Duropolymer®
Designed by
Orio Tonini



CX196 U-STEPS
200 x 11,3 x 4 cm
Duropolymer®
Designed by
Orio Tonini





CX197 U-STEPS
200 x 9,3 x 5 cm
Duropolymer®
Designed by
Orio Tonini

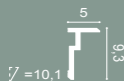

PX198 U-STEPS
200 x 2 x 8,3 cm
Duropolymer®
Designed by
Orio Tonini



PX164
200 x 3 x 2,4 cm
Duropolymer®



SX162 | SX162F SQUARE
200 x 1 x 4 cm
Duropolymer®



CB520
200 x 3,5 x 3,5 cm
Durofoam®

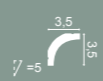

CB521
200 x 5 x 5 cm
Durofoam®



CB522
200 x 6,7 x 6,7 cm
Durofoam®



CB524
200 x 9 x 9 cm
Durofoam®

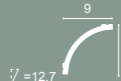

CB523
200 x 5,9 x 4,4 cm
Durofoam®



SX157 | SX157F SQUARE
200 x 1,3 x 6,6 cm
Duropolymer®



SX163 | SX163F SQUARE
200 x 1,3 x 10,1 cm
Duropolymer®



SX182 | SX182F CASCADE
200 x 1,3 x 5 cm
Duropolymer®



SX183 | SX183F CASCADE
200 x 1,3 x 7,5 cm
Duropolymer®



CB525
200 x 6,5 x 6 cm
Durofoam®



CB510
200 x 4 x 4 cm
Durofoam®



CB511
200 x 6,7 x 6,7 cm
Durofoam®



CB512
200 x 9 x 9 cm
Durofoam®



CB530
200 x 2,7 x 1,5 cm
Durofoam®

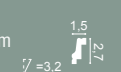

SX184 | SX184F CASCADE
200 x 1,3 x 11 cm
Duropolymer®



CX160
200 x 1,3 x 3,9 cm
Duropolymer®



CX161
200 x 1,3 x 6,9 cm
Duropolymer®



PB513
200 x 1,5 x 3,4 cm
Durofoam®



CB531
200 x 4,8 x 2,6 cm
Durofoam®



CB500
200 x 2,5 x 1,8 cm
Durofoam®



CB501
200 x 4,1 x 3,5 cm
Durofoam®

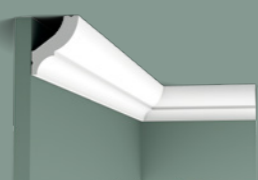

CB502
200 x 5,9 x 4,9 cm
Durofoam®



CB503
200 x 8,2 x 9,2 cm
Durofoam®



Skirting Boards

PLINTEN / PLINTHES
SOCKELLEISTEN / ZÓCALOS / BATTISCOPIA

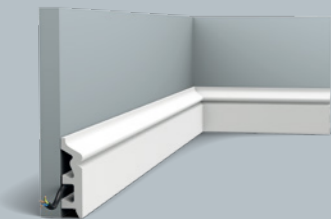

SX122
200 x 7,9 x 2,2 cm
Duropolymer®

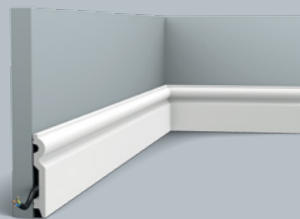

SX137 | SX137F
200 x 10 x 1,5 cm
Duropolymer®

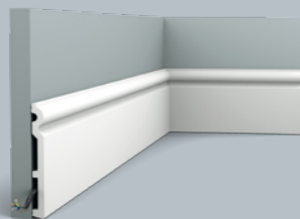

SX138 | SX138F
200 x 13,8 x 1,5 cm
Duropolymer®

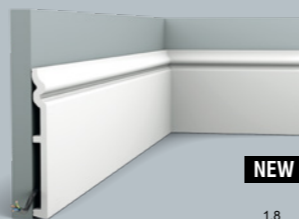

SX206 CONTOUR
200 x 18 x 1,8 cm
Duropolymer®



NEW

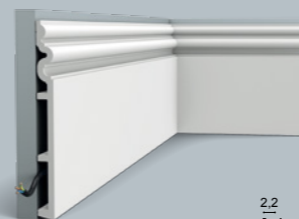

1 SX193 AUTOIRE
200 x 25 x 2,2 cm
Duropolymer®
Designed by
Orio Tonini



1. SX193 p.52 | 2. W120 p.76

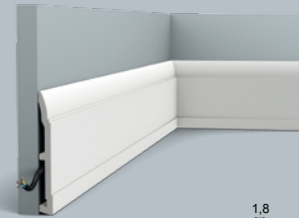

SX104 | SX104F
200 x 14,8 x 1,7 cm
Duropolymer®

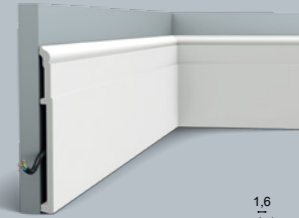
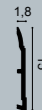

SX156 HIGH HEELS
200 x 20,2 x 1,6 cm
Duropolymer®
Designed by
Xavier Donck



SX191 HIGH RISE
200 x 21 x 2,1 cm
Duropolymer®

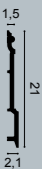

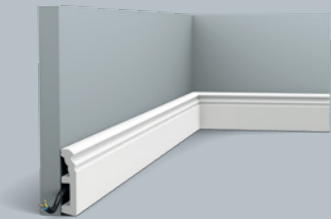

1 SX195 | SX195F HAMBURG
200 x 8 x 1,9 cm
Duropolymer®



54



SX105 | SX105F
200 x 10,8 x 1,3 cm
Duropolymer®



SX155 | SX155F
200 x 10,8 x 2,5 cm
Duropolymer®



1. SX195 p.54 | 2. P8030 p.62 | 3.W113 p.73

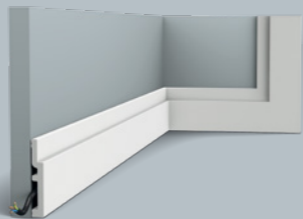

SX187 | SX187F HIGH LINE
200 x 7,5 x 1,2 cm
Duropolymer®
Designed by
Pierre Daems

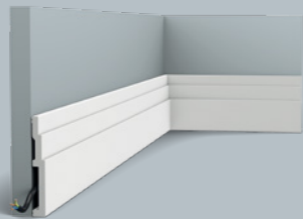

SX180 | SX180F HIGH LINE
200 x 12 x 1,6 cm
Duropolymer®
Designed by
Pierre Daems

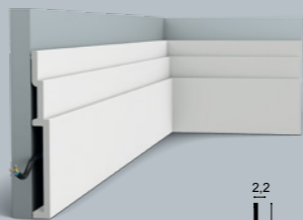

SX181 HIGH LINE
200 x 20 x 2,2 cm
Duropolymer®
Designed by
Pierre Daems

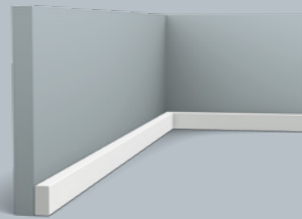

SX194 | SX194F SQUARE
200 x 2 x 1 cm
Duropolymer®

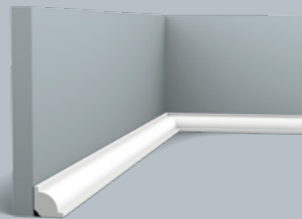

CX132 | CX132F
200 x 2 x 2 cm
Duropolymer®

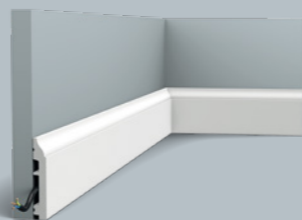

SX172 | SX172F
200 x 8,5 x 1,4 cm
Duropolymer®

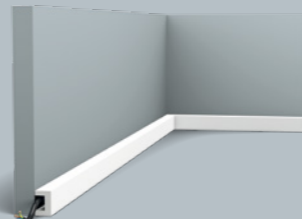

CX190 | CX190F U-PROFILE
200 x 3 x 2 cm
Duropolymer®
Designed by
Orio Tonini

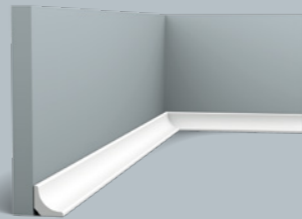

CX133
200 x 2 x 2 cm
Duropolymer®

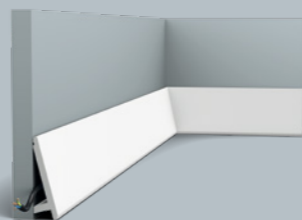

SX179 DIAGONAL
200 x 9,7 x 2,9 cm
Duropolymer®
Designed by
Orio Tonini

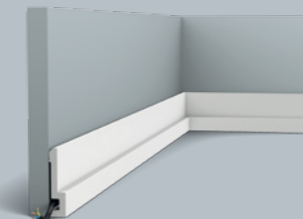
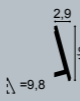

PX198 U-STEPS
200 x 8,3 x 2 cm
Duropolymer®

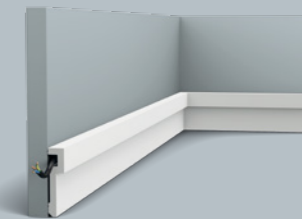

PX198 U-STEPS
200 x 8,3 x 2 cm
Duropolymer®

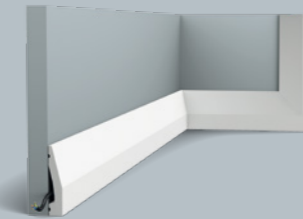

SX159
200 x 6 x 1,2 cm
Duropolymer®

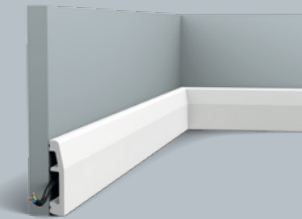

SX125
200 x 6,9 x 1,4 cm
Duropolymer®



55

Skirting Boards



The Perfect Finish
PG. 92 - 93

Multifunctional

MULTIFUNCTIONEEL
MULTIFONCTIONNEL
MULTIFUNKTIONAL
MULTIFUNCIONAL
MULTIFUNZIONALE



en —

Profiles with endless possibilities. Each element can be used as a panel moulding, cornice moulding, door surround or as skirting board.

nl —

Profielen met oneindig veel mogelijkheden. Één en hetzelfde profiel kan zowel als wand-, kroonlijst, deuromlijsting of plint gebruikt worden.

fr —

Des profils avec des possibilités illimitées. Un même profil peut être utilisé comme décoration murale: comme encadrement de porte, corniche, cimaise ou comme plinthe.

de —

Profil mit unzähligen Möglichkeiten. Das gleiche Element kann als Wandleiste, Eckleiste, Türumrandung oder Sockelleiste verwendet werden.

es —

Molduras con un sinfín de posibilidades. El mismo y único elemento se puede utilizar como moldura, cornisa, marco para puertas o como zócalo.

it —

Profili con infinite possibilità d'uso. Lo stesso elemento può essere utilizzato sia come cornice soffitto, cornice parete, contorno porta e come battiscopa.



1. SX105 p.54 | 2. SX163 p.57

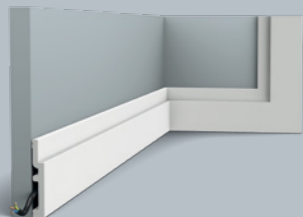

SX187 | SX187F HIGH LINE
200 x 7,5 x 1,2 cm
Duropolymer®
Designed by Pierre Daems

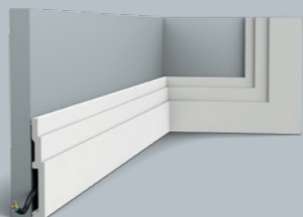

SX180 | SX180F HIGH LINE
200 x 12 x 1,6 cm
Duropolymer®
Designed by Pierre Daems

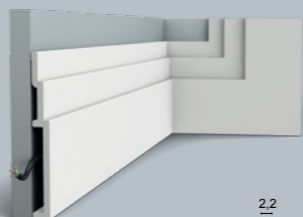

SX181 HIGH LINE
200 x 20 x 2,2 cm
Duropolymer®
Designed by Pierre Daems

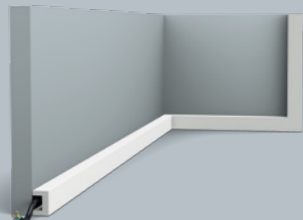

CX190 | CX190F U-PROFILE
200 x 3 x 2 cm
Duropolymer®
Designed by Orio Tonini

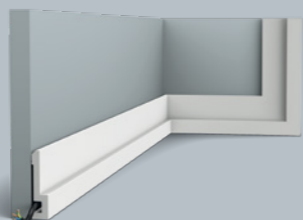

PX198 U-STEPS
200 x 8,3 x 2 cm
Duropolymer®

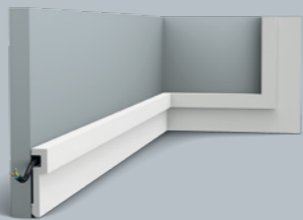

PX198 U-STEPS
200 x 8,3 x 2 cm
Duropolymer®

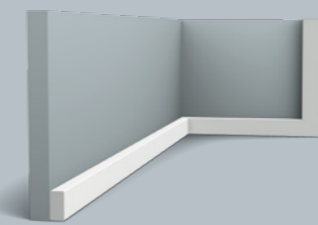

SX194 | SX194F SQUARE
200 x 2 x 1 cm
Duropolymer®

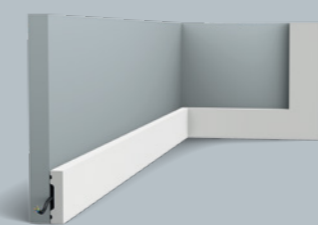

SX162 | SX162F SQUARE
200 x 4 x 1 cm
Duropolymer®

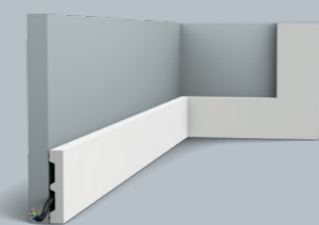

SX157 | SX157F SQUARE
200 x 6,6 x 1,3 cm
Duropolymer®

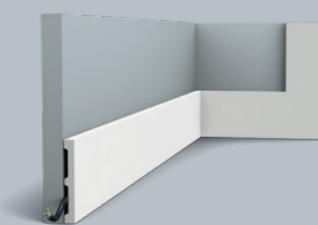

SX163 | SX163F SQUARE
200 x 10,1 x 1,3 cm
Duropolymer®

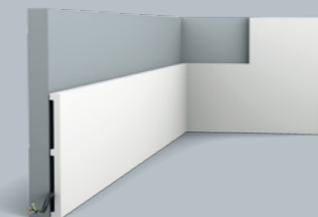

SX168 SQUARE
200 x 15,1 x 1,4 cm
Duropolymer®

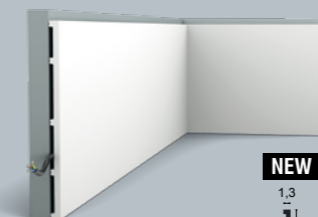

SX207 SQUARE
200 x 25 x 1,3 cm
Duropolymer®

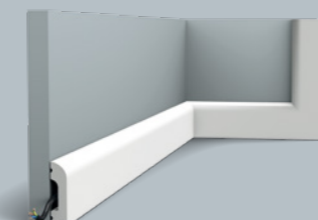

SX182 | SX182F CASCADE
200 x 5 x 1,3 cm
Duropolymer®

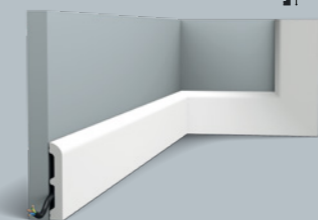

SX183 | SX183F CASCADE
200 x 7,5 x 1,3 cm
Duropolymer®

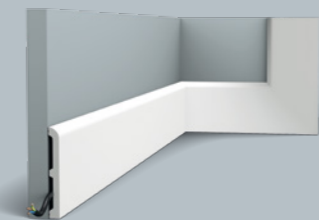

SX184 | SX184F CASCADE
200 x 11 x 1,3 cm
Duropolymer®

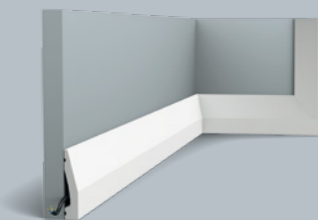

SX159
200 x 6 x 1,2 cm
Duropolymer®



3 essential Skirting Board families CHOOSE YOUR STYLE. GET CREATIVE.

SMALL

MEDIUM

BIG

COVER



SQUARE

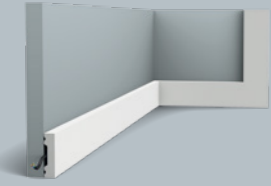

SX162 | SX162F SQUARE
200 x 4 x 1 cm
Duropolymer®

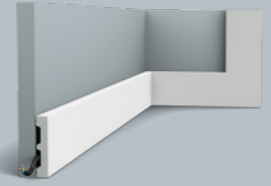

SX157 | SX157F SQUARE
SX157-RAL9003
200 x 6,6 x 1,3 cm
Duropolymer®

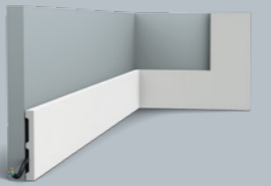

SX163 | SX163F SQUARE
SX163-RAL9003
200 x 10,1 x 1,3 cm
Duropolymer®

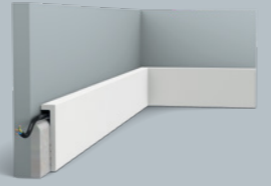

SX171 SQUARE
SX171-RAL9003
200 x 10 x 2,2 cm
Duropolymer®

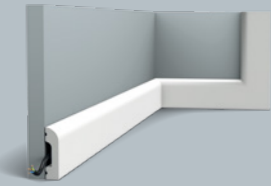

SX182 | SX182F CASCADE
200 x 5 x 1,3 cm
Duropolymer®

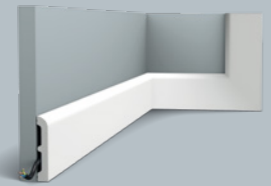

SX183 | SX183F CASCADE
SX183-RAL9003
200 x 7,5 x 1,3 cm
Duropolymer®

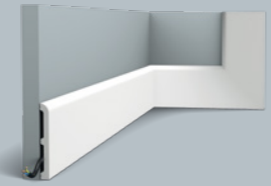

SX184 | SX184F CASCADE
SX184-RAL9003
200 x 11 x 1,3 cm
Duropolymer®

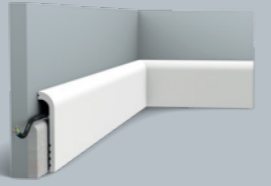

SX185 CASCADE
200 x 12 x 2,5 cm
Duropolymer®

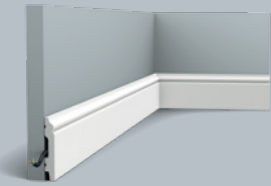
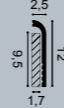

SX165 | SX165F CONTOUR
200 x 6,9 x 1,1 cm
Duropolymer®

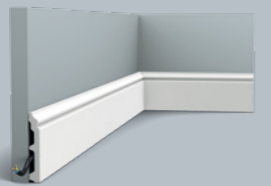

SX173 | SX173F CONTOUR
SX173-RAL9003
200 x 10 x 1,6 cm
Duropolymer®

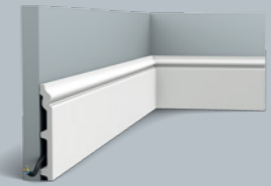

SX118 | SX118F CONTOUR
SX118-RAL9003
200 x 13,8 x 1,8 cm
Duropolymer®

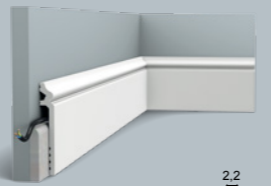

SX186 CONTOUR
200 x 13,8 x 2,2 cm
Duropolymer®



CASCADE



CONTOUR

Cover Skirting Boards

OVERZETPLINTEN / SURPLINTHES
ABDECK-SOCKELLEISTEN / CUBRE RODAPIÉ
COPRI BATTISCOPIA



nl
3 families plinten.
Kies je stijl. Wees creatief.

fr
3 familles de plinthes.
Choisissez votre style.
Faites preuve de créativité.

de
3 Sockelleisten-Familien.
Wählen Sie Ihren Stil.
Seien Sie kreativ.

es
3 familias de zócalos.
Elije tu estilo. Se creativo.

it
3 famiglie di battiscopa essenziali.
Scegli il tuo stile. Esprimi la tua creatività.



PAINTABLE
Overschilderbaar
Peut être peint
Überstreichbar
Fácil de pintar
Verniciabile



WATER RESISTANT
Waterbestendig
Résistant à l'eau
Wasserfest
Resistente al agua
Resistente all'acqua



IDEAL FOR RENOVATIONS
Ideaal voor renovatie
Idéal pour des rénovations
Ideal für die Renovierung
Ideal para renovaciones
Ideale per le ristrutturazioni

1. SX185 p.59 | 2. PX175 p.66

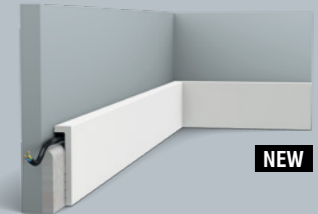

NEW

SX171 SQUARE
SX171-RAL9003
200 x 10 x 2,2 cm
Duropolymer®

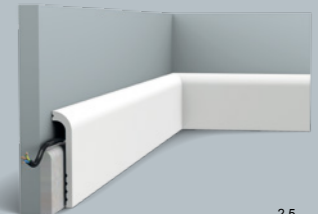
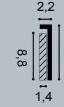

SX185 CASCADE
200 x 12 x 2,5 cm
Duropolymer®

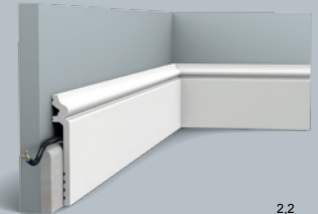
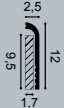

SX186 CONTOUR
200 x 13,8 x 2,2 cm
Duropolymer®

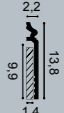

DUROPOLYMER® LOVES...

nl —

Duropolymer® houdt van verf, is reeds geprimed en makkelijk af te werken met kwaliteitsverf. Duropolymer® houdt van water maar wordt nooit nat, is waterbestendig en dimensioneel stabiel. Duropolymer blinkt uit met haarscherpe lijnen en fijne weergave van alle details. Duropolymer® houdt van hard werk en is bijzonder schok-, impact- en krasbestendig. Duropolymer® blijft graag hangen, is lichtgewicht en makkelijk te installeren met de Orac Decor® DecoFix lijmen. Duropolymer® is duurzaam, wordt geproduceerd met 40% hernieuwbare energie, is 100% recycleerbaar en bevat geen toxische stoffen.

fr —

Duropolymer® aime la peinture, est livré avec un apprêt et est facile à finir avec n'importe quel type de peinture de qualité. Duropolymer® aime l'eau mais ne devient jamais humide, résiste à l'eau et est dimensionnellement stable. Duropolymer® aime se démarquer par ses bords tranchants et ses détails raffinés pour un design haute définition. Duropolymer® aime travailler, résiste aux chocs, aux rayures et aux impacts. Duropolymer® aime bien se tenir, est léger et facile à installer avec les colles Orac Decor® DecoFix. Duropolymer® aime la durabilité, est fabriqué avec un recyclage intégré, est 100 % recyclable et ne contient aucun produit toxique.

de —

Duropolymer® liebt Farbe, wird bereits grundiert geliefert und lässt sich leicht mit jeder Art von hochwertiger Farbe veredeln. Duropolymer® liebt Wasser, wird aber nie nass – es ist wasserfest und formstabil. Duropolymer® liebt es, sich durch klar definierte Kanten und präzise Details auszuzeichnen – für ein hochwertiges Design. Duropolymer® liebt harte Arbeit – es ist robust, stoß-, schlag- und kratzfest. Duropolymer® liebt es, an Wand und Decke zu hängen – es ist ein Leichtgewicht und mit den DecoFix-Klebern von Orac Decor® ganz einfach anzubringen. Duropolymer® liebt Nachhaltigkeit, wird recyclingfähig hergestellt, ist zu 100 % wiederverwertbar und enthält keine toxischen Produkte.

es —

Duropolymer® admite a la perfección la pintura, viene imprimado y es fácil de terminar con cualquier tipo de pintura de calidad. A Duropolymer® le encanta el agua, pero nunca se moja, es impermeable y de dimensiones estables. Resulta ideal para hacerlo resaltar con bordes afilados y detalles finos que le confieran un diseño de alta definición. A Duropolymer® le gusta el trabajo duro, y es resistente a golpes, impactos y arañazos. También le encanta quedar colgado; es ligero y fácil de instalar con pegamentos Orac Decor® DecoFix. Ante todo, es un material sostenible. Se elabora a partir de un reciclaje integrado, es 100 % reciclable y no contiene productos tóxicos.

it —

Duropolymer® ama la vernice, viene fornito primerizzato ed è facile da rifinire con qualsiasi tipo di vernice di qualità. Duropolymer® ama l'acqua, ma non si bagna mai, è impermeabile e ha dimensioni stabili. Duropolymer® ama distinguersi con bordi definiti e dettagli raffinati per un design ad alta definizione. Duropolymer® è resistente agli urti e ai graffi. Duropolymer® è leggero e facile da installare con le colle Orac Decor® DecoFix. Duropolymer® ama la sostenibilità, è prodotto con riciclaggio integrato, è riciclabile al 100% e non contiene prodotti tossici.



PAINT

primed and easy to finish with any type of quality paint



WATER

but never gets wet; water resistant and dimensionally stable



TO STAND OUT

sharp edges and fine details for high-definition design



HARD WORK

knock-, impact- and scratch-resistant



TO HANG AROUND

lightweight and easy to install with Orac Decor® DecoFix glues



SUSTAINABILITY

produced with 40% renewable energy, 100% recyclable, contains no toxic products

Panel Mouldings

WANDLIJSTEN / CIMAISES
WAND - UND FRIESLEISTEN / MOLDURAS
CORNICI PARETE

62

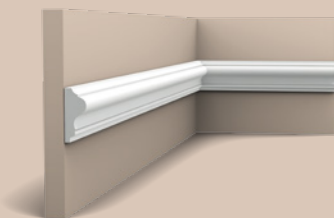

2 P8030 | P8030F
200 x 4,1 x 1,7 cm
Purotouch[®]

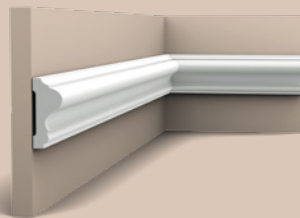

P8020 | P8020F
200 x 6 x 2,6 cm
Purotouch[®]

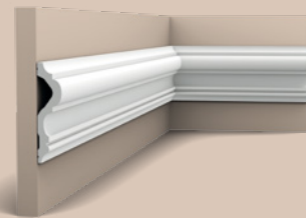

P8050 | P8050F
200 x 12 x 3 cm
Purotouch[®]

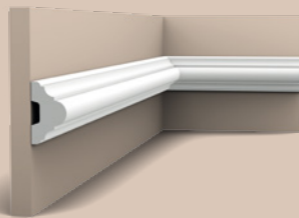

P4020 | P4020F
200 x 5 x 2,9 cm
Purotouch[®]

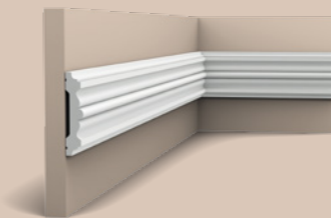

P9020
200 x 9,6 x 2,1 cm
Purotouch[®]

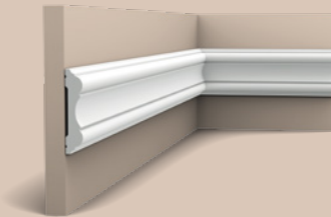

P8040 | P8040F
200 x 10,1 x 2,2 cm
Purotouch[®]

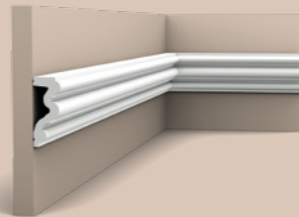

P4025 | P4025F AUTOIRE
200 x 8,3 x 3,4 cm
Purotouch[®]
Designed by
Orio Tonini

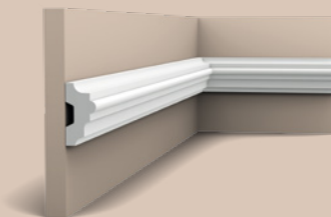

P9040
200 x 5 x 2,5 cm
Purotouch[®]

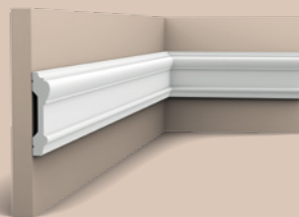

P9010 | P9010F
200 x 9,1 x 3 cm
Purotouch[®]



1. SX118 p.58 | 2. P8030 p.62

63

Panel Mouldings

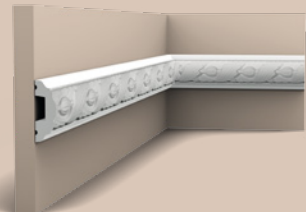

P1020
200 x 4,9 x 2,4 cm
Purotouch[®]

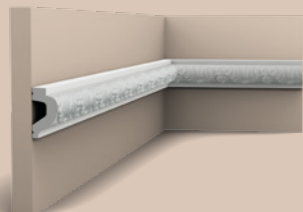

P3020 | P3020F
200 x 6,1 x 3,2 cm
Purotouch[®]



1. P.3071 p.65

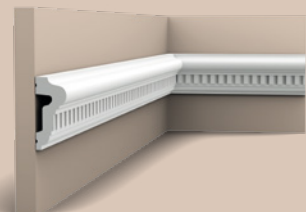

P6020
200 x 6,4 x 2,8 cm
Purotouch[®]

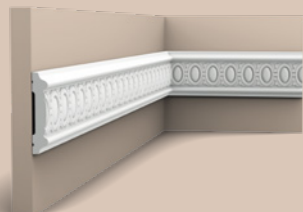

P7030
200 x 8,5 x 1,7 cm
Purotouch[®]

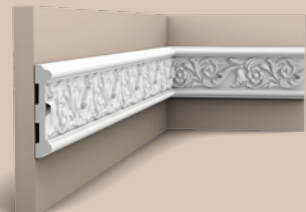

P7020
200 x 11,1 x 1,9 cm
Purotouch[®]

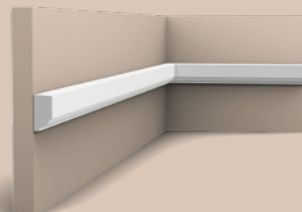

P9050 | P9050F
200 x 2,5 x 1,3 cm
Purotouch[®]

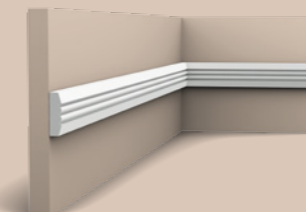

P5021 | P5021F
200 x 3,1 x 0,9 cm
Purotouch[®]

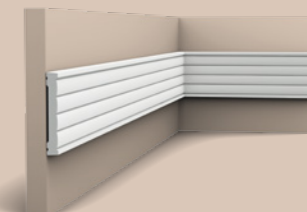

P5020
200 x 9,1 x 1,3 cm
Purotouch[®]

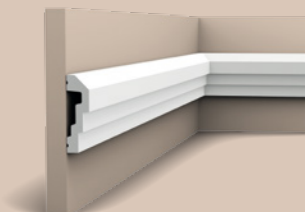

P7070 | P7070F
200 x 7,4 x 2,2 cm
Purotouch[®]

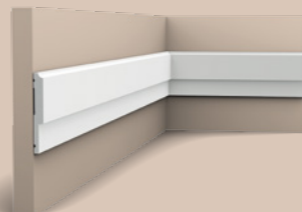

P9900 | P9900F
200 x 8 x 1 cm
Purotouch[®]

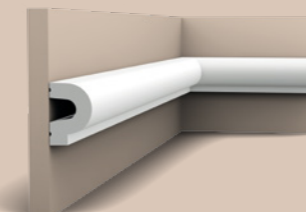

P8060
200 x 5 x 3,5 cm
Purotouch[®]

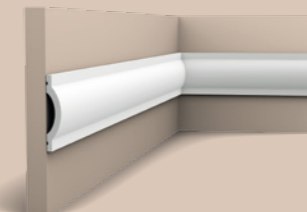

P9901
200 x 7 x 1,4 cm
Purotouch[®]

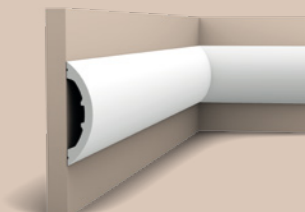

P3070 RADIUS
200 x 12,5 x 3,2 cm
Purotouch[®]
Designed by Ulf Moritz

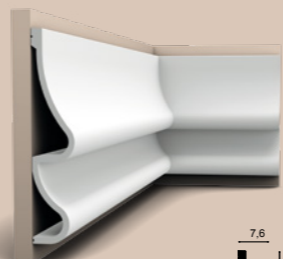

1. P3071 GOLF
200 x 37,2 x 7,6 cm
Purotouch[®]
Designed by Ulf Moritz



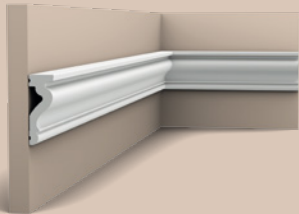

DX174-2300 | DX174F
230 x 6 x 2,2 cm (DX174-2300)
Duropolymer®
200 x 6 x 2,2 cm (DX174F)

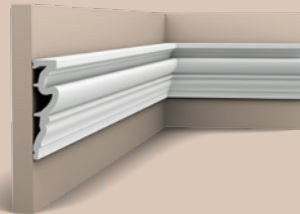

DX170-2300
230 x 11,9 x 3,2 cm
Duropolymer®

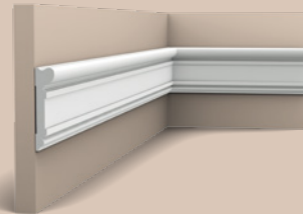

DX119-2300
230 x 9,2 x 2,2 cm
Duropolymer®

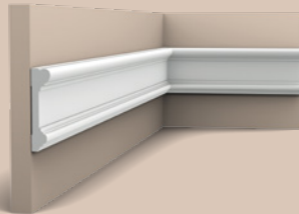

DX121-2300
230 x 9,4 x 2,3 cm
Duropolymer®

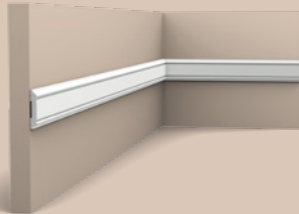

PX144 | PX144F
200 x 4,7 x 0,8 cm
Duropolymer®

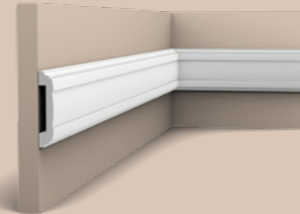

PX102
200 x 7,9 x 1,6 cm
Duropolymer®

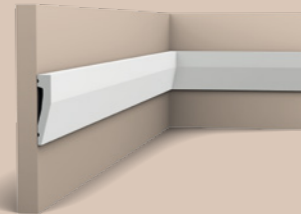

SX159
200 x 6 x 1,2 cm
Duropolymer®

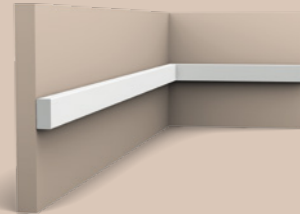

SX194 | SX194F SQUARE
200 x 2 x 1 cm
Duropolymer®

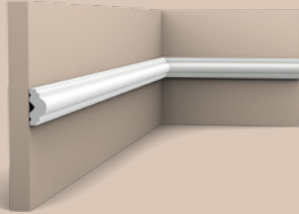

PX103 | PX103F
200 x 2,5 x 1,2 cm
Duropolymer®

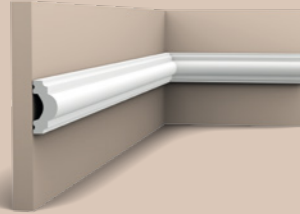

PX120 | PX120F
200 x 4 x 1,9 cm
Duropolymer®

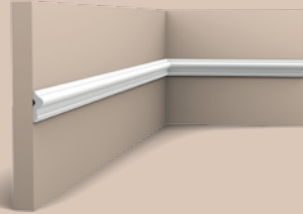

PX201 | PX201F
200 x 2,5 x 0,9 cm
Duropolymer®

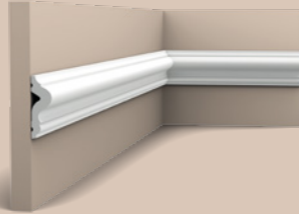

PX175 | PX175F
200 x 5 x 1,7 cm
Duropolymer®

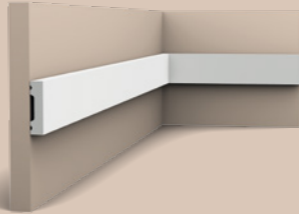

SX162 | SX162F SQUARE
200 x 4 x 1 cm
Duropolymer®

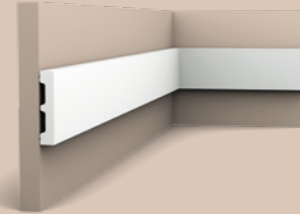

SX157 | SX157F SQUARE
200 x 6,6 x 1,3 cm
Duropolymer®

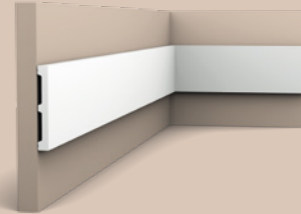

SX163 | SX163F SQUARE
200 x 10,1 x 1,3 cm
Duropolymer®

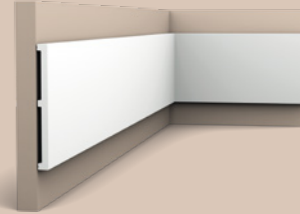

SX168 SQUARE
200 x 15,1 x 1,4 cm
Duropolymer®

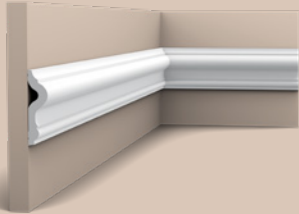

PX202 | PX202F
200 x 7,5 x 5 cm
Duropolymer®

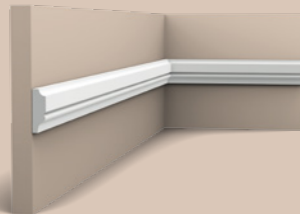

PX116
200 x 3,1 x 1 cm
Duropolymer®

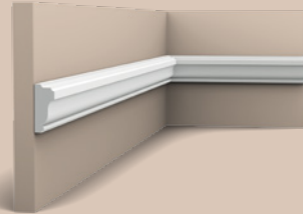

PX117
200 x 3,5 x 1,5 cm
Duropolymer®

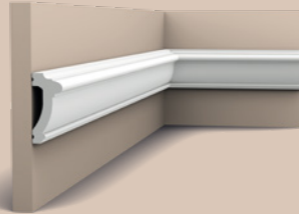

PX113
200 x 6 x 2,7 cm
Duropolymer®

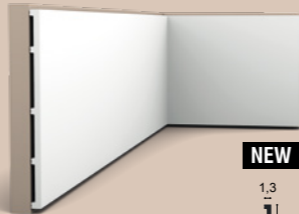

SX207 SQUARE
200 x 25 x 1,3 cm
Duropolymer®

NEW

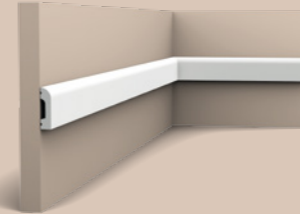

SX182 | SX182F CASCADE
200 x 5 x 1,3 cm
Duropolymer®

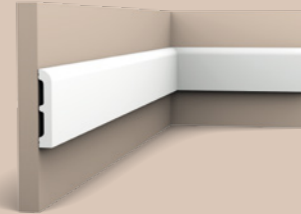

SX183 | SX183F CASCADE
200 x 7,5 x 1,3 cm
Duropolymer®

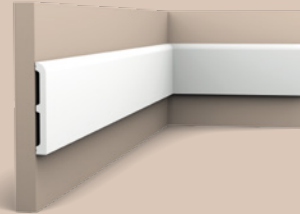

SX184 | SX184F CASCADE
200 x 11 x 1,3 cm
Duropolymer®



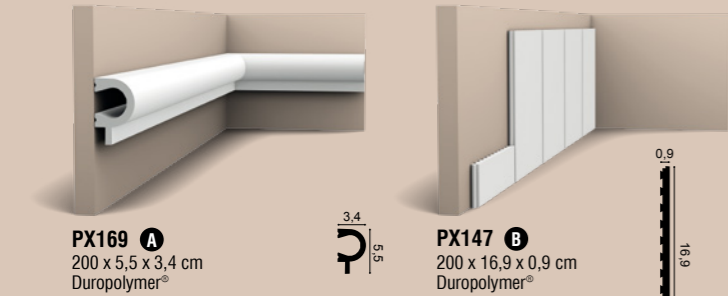

PX169 A
200 x 5,5 x 3,4 cm
Duropolymer®

PX147 B
200 x 16,9 x 0,9 cm
Duropolymer®

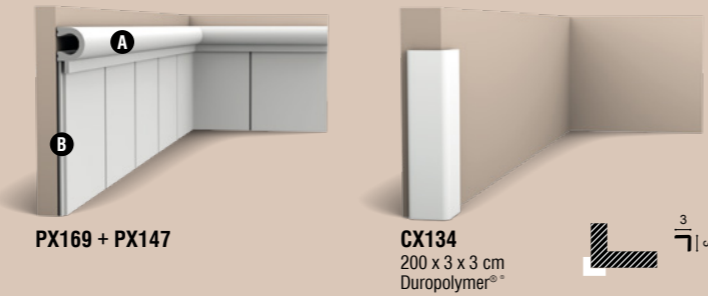

PX169 + PX147

CX134
200 x 3 x 3 cm
Duropolymer®

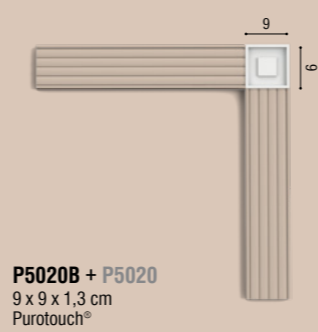

P5020B + P5020
9 x 9 x 1,3 cm
Purotouch®



P101A + P1020
24,5 x 24,5 x 2,4 cm
Purotouch®



P801C + P8020
19,8 x 11 x 2,6 cm
Purotouch®



P4020A + P4020
16,4 x 9,1 x 2,9 cm
Purotouch®

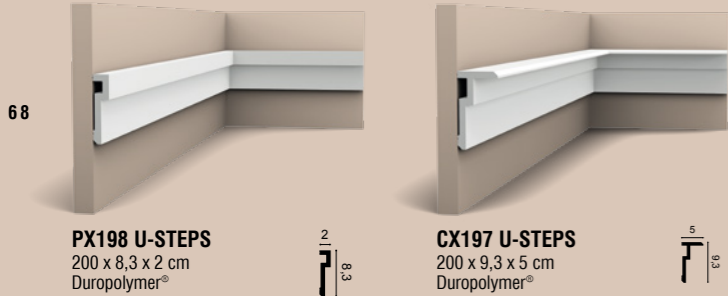

PX198 U-STEPS
200 x 8,3 x 2 cm
Duropolymer®

PX197 U-STEPS
200 x 9,3 x 5 cm
Duropolymer®



P3020A + P3020
42,5 x 42,5 x 4 cm
Purotouch®

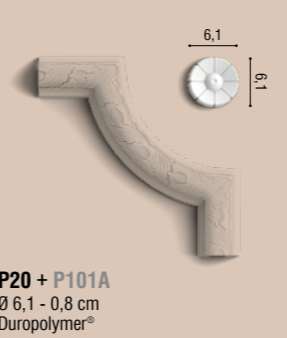

P20 + P101A
Ø 6,1 - 0,8 cm
Duropolymer®

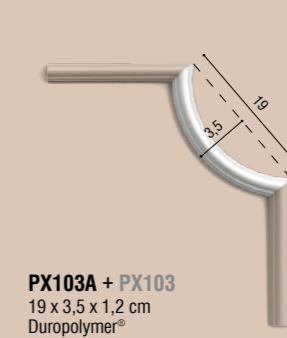

PX103A + PX103
19 x 3,5 x 1,2 cm
Duropolymer®



P8030D + P8030
13,2 x 13,2 x 1,7 cm
Duropolymer®

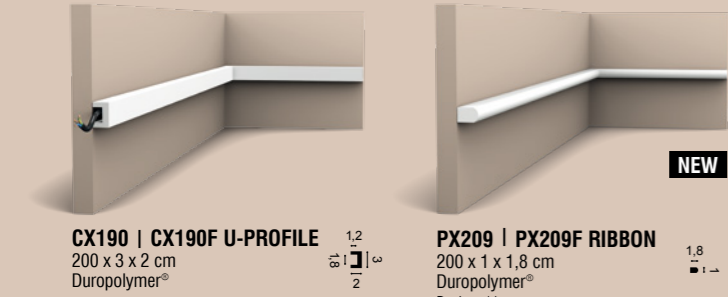

CX190 | CX190F U-PROFILE
200 x 3 x 2 cm
Duropolymer®

PX209 | PX209F RIBBON
200 x 1 x 1,8 cm
Duropolymer®
Designed by
Orio Tonini



1. PX120 p.66 | 2. SX156 p.53 | 3. P3020A p.69 | 4. P3020 p.64

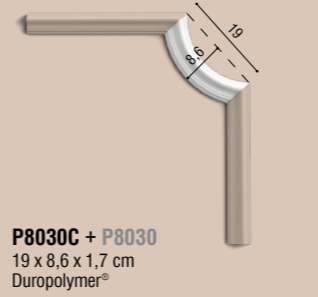

P8030C + P8030
19 x 8,6 x 1,7 cm
Duropolymer®



PX120A + PX120
19 x 8,8 x 2 cm
Duropolymer®

The Perfect Finish
PG. 92 - 93



3D Wall Covering

3D WANDBEKLEIDING / REVÊTEMENTS MURAU 3D
 3D WANDVERTÄFELUNG
 REVESTIMIENTO DE PARED 3D
 RIVESTIMENTO MURALE 3D

70



1. SX118 p.58 | 2. PX209 p.68 | 3. W109 p.70 | 4. W212 p.70 | 5. SX168 p.57

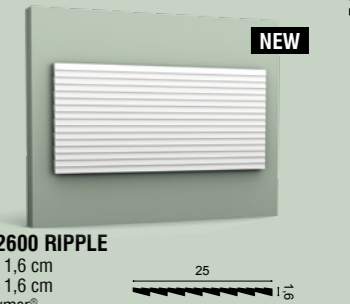
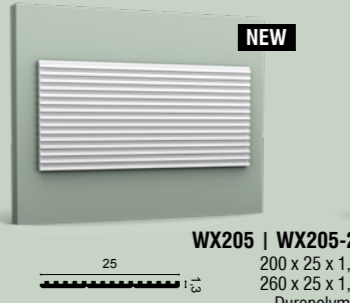
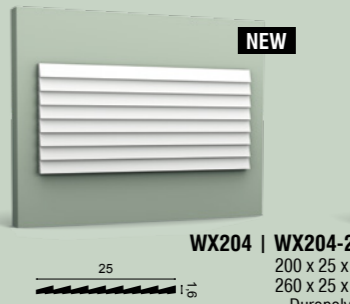
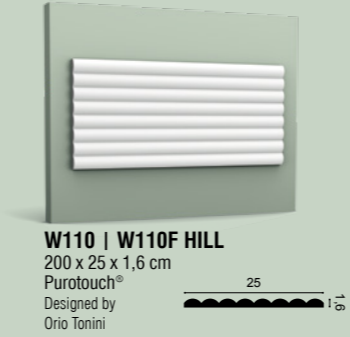
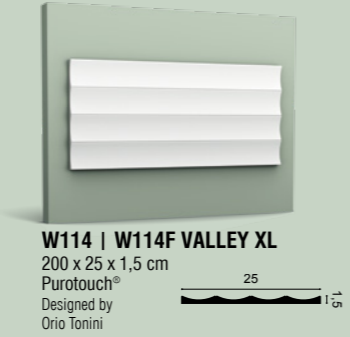
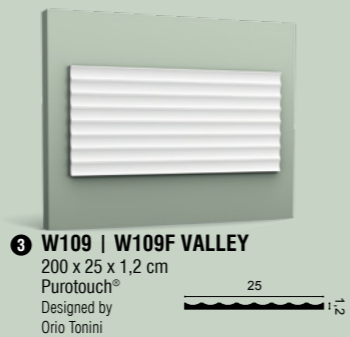

6. SX194 p.57 | 7. WX204 p.71 | 8. CX190 p.82



71

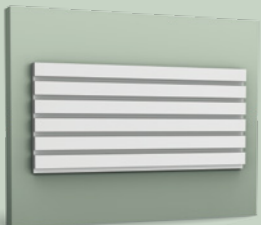

2 3 W111 | W111F BAR
 200 x 25 x 2 cm
 Purotouch®
 Designed by Orio Tonini

W111 + 2x CX190



5 W116 | W116F BAR XL
 200 x 25 x 2 cm
 Purotouch®
 Designed by Orio Tonini

W116 + 2x CX190



1 4 W119 | W119F BAR MIX
 200 x 25 x 2 cm
 Purotouch®
 Designed by Orio Tonini



1. W119F p.72 | 2. W111F p.72 | 3. W111 p.72 | 4. W119 p.72
 5. W116 p.72 | 6. PX198F p.68 | 7. CX190F p.82

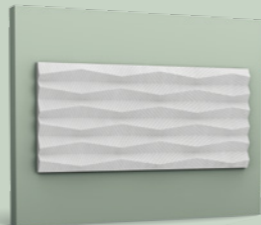

W112 RIDGE
 200 x 25 x 1,9 cm
 Purotouch®
 Designed by Orio Tonini

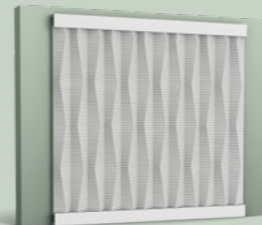

W112 + 2x CX190

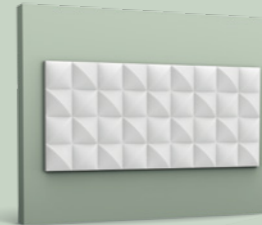

W113 COBBLE
 200 x 25 x 2,18 cm
 Purotouch®
 Designed by Orio Tonini

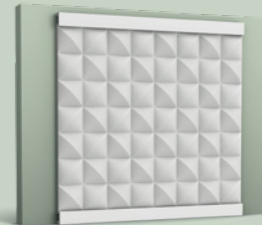

W113 + 2x CX190



W130 CHEVRON
 200 x 40 x 2 cm
 Purotouch®



W130 + 2x CX190

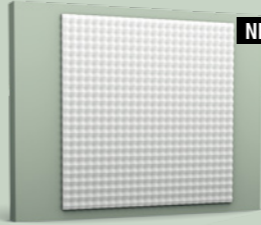

11 W117 SLOPE
 100 x 100 x 2,3 cm
 Purotouch®
 Designed by Orio Tonini



SX207 SQUARE
 200 x 25 x 1,3 cm
 Duropolymer®



9. PX198 p.55 | 10. CX190 p.55 | 11. W117 p.73

Positive Thermal & Acoustic Effects

Purotouch®

POSITIEVE THERMISCHE EN AKOESTISCHE EFFECTEN
EFFETS THERMIQUES ET ACOUSTIQUES POSITIFS
POSITIVE THERMISCHE UND AKUSTISCHE WIRKUNG
AISLAMIENTO TÉRMICO Y ACÚSTICO
EFFETTI TERMICI E ACUSTICI POSITIVI



THERMAL INSULATION

Thermische isolatie | Isolation thermique
Thermische Dämmung
Aislamiento térmico
Isolamento termico

$\lambda = 0,029 \text{ W/mK} - R = 0,55 \text{ m}^2\text{K/W}$

Equals effect of insulation board
of the same thickness.

Gelijk aan het effect van isolatieplaten
van dezelfde dikte.

Avec le même effet que des panneaux isolants
de la même épaisseur.

Gleiche Wirkung wie eine Dämmplatte gleicher Stärke.

Igual efecto del tablero aislante del mismo espesor.

Ugual effetto del pannello isolante dello stesso spessore.



ACOUSTIC ABSORPTION

Akoestische absorptie | Absorption
acoustique | Schallabsorption
Absorción acústica
Assorbimento acustico

CLASS E

Absorbs up to 25% of a conversation.

Absorbeert tot 25% van een gesprek.

Absorbe jusqu'à 25% des conversations.

Absorbiert bis zu 25% des Raumschalls.

Absorbe hasta el 25% de una conversación.

Assorbe fino al 25% di una conversazione.

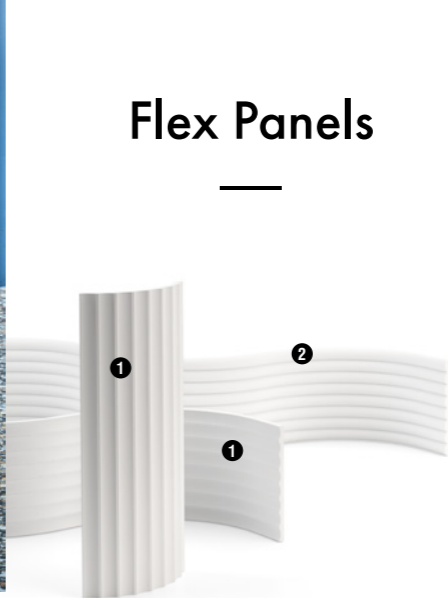

Flex Panels

Our wall panels ZIGZAG, VALLEY (XL), HILL (XL) and BAR are now also available in a flexible version.

Onze wandpanelen ZIGZAG, VALLEY (XL), HILL (XL) en BAR zijn nu ook verkrijgbaar in een flexibele variant.

Nos panneaux muraux ZIGZAG, VALLEY (XL), HILL (XL) et BAR sont désormais également disponibles en version flexible.

Unsere Wandpaneel ZIGZAG, VALLEY (XL), HILL (XL) und BAR sind jetzt auch in einer flexiblen Version erhältlich.

Nuestros paneles de pared ZIGZAG, VALLEY (XL), HILL (XL) y BAR ahora también están disponibles en una versión flexible.

I nostri pannelli da parete ZIGZAG, VALLEY (XL), HILL (XL) e BAR sono ora disponibili anche in una versione flessibile.

W108 | W108F ZIGZAG

200 x 25 x 1,8 cm
Purotouch®
Designed by
Orio Tonini

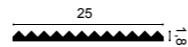

W110 | W110F HILL

200 x 25 x 1,6 cm
Purotouch®
Designed by
Orio Tonini

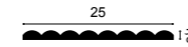

W109 | W109F VALLEY

200 x 25 x 1,2 cm
Purotouch®
Designed by
Orio Tonini

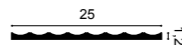

W114 | W114F VALLEY XL

200 x 25 x 1,5 cm
Purotouch®
Designed by
Orio Tonini

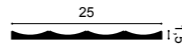

W111 | W111F BAR

200 x 25 x 2 cm
Purotouch®
Designed by
Orio Tonini

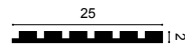

W116 | W116F BAR XL

200 x 25 x 2 cm
Purotouch®
Designed by
Orio Tonini

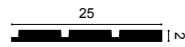

W119 | W119F BAR MIX

200 x 25 x 2 cm
Purotouch®
Designed by
Orio Tonini

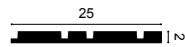

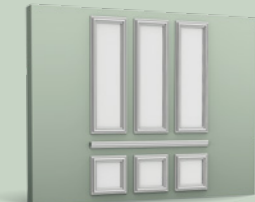

W120 + P4025 + W121
Purotouch®
Designed by
Oriio Tonini



6 W120 AUTOIRE A
50 x 150 x 3,2 cm
Purotouch®
Designed by
Oriio Tonini

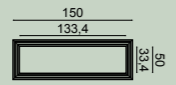

2 W121 AUTOIRE B
50 x 50 x 3,2 cm
Purotouch®
Designed by
Oriio Tonini

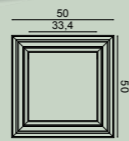

W100 ROMBUS
25,8 x 15 x 2,9 cm
Purotouch®

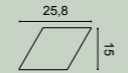

W101 TRAPEZIUM
34,5 x 15 x 2,9 cm
Purotouch®

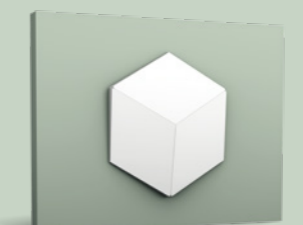
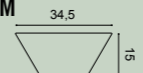

W105 ROMBUS
30 x 34,6 x 3 cm
Purotouch®

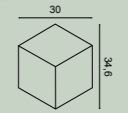

F30
59,5 x 59,5 x 4,3 cm
Purotouch®

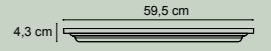

4 W122 AUTOIRE C
33,3 x 33,3 x 2,6 cm
Purotouch®
Designed by
Oriio Tonini

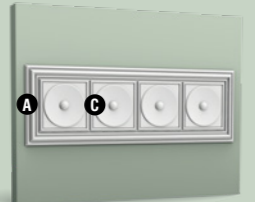
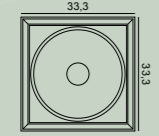

W120 + 4*W122
Purotouch®

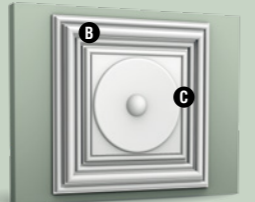

W121 + W122
Purotouch®



5 W123 AUTOIRE D
33,3 x 33,3 x 3,5 cm
Purotouch®
Designed by
Oriio Tonini

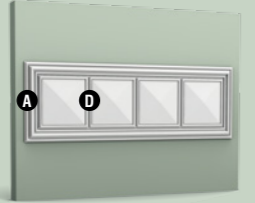
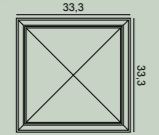

W120 + 4*W123
Purotouch®

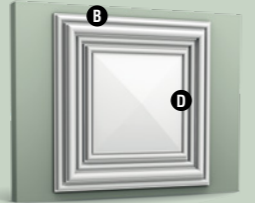

W121 + W123
Purotouch®



W102 CUBI
33,3 x 33,3 x 2,5 cm
Purotouch®

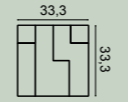

W103 CUBI
33,3 x 33,3 x 2,5 cm
Purotouch®

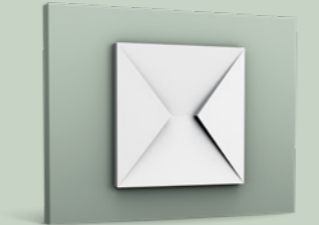
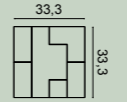

8 W106 ENVELOP
33,3 x 33,3 x 2,9 cm
Purotouch®

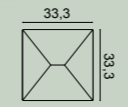

9 W107 CIRCLE
33,3 x 33,3 x 2,9 cm
Purotouch®

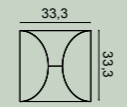

1. SX138 p.52 | 2. W121 p.76 | 3. P4020 p.62 | 4. W122 p.76 | 5. W123 p.76 | 6. W120 p.76 | 7. C324 p.78

8. W106 p.77 | 9. W107 p.77

Led Coving

INDIRECTE VERLICHTING / ÉCLAIRAGE INDIRECT
INDIREKTE BELEUCHTUNG / ILUMINACIÓN INDIRECTA
ILLUMINAZIONE INDIRECTA

78



C323
200 x 5,5 x 4,2 cm
Purotouch®



C324 AUTOIRE
200 x 8,3 x 3,4 cm
Purotouch®
Designed by
Orio Tonini



1. SX138 p.52 | 2. D330LR p.88 | 3. DX170-2300 p.88 | 4. W121 p.76 | 5. W120 p.76 | 6. C324 p.78

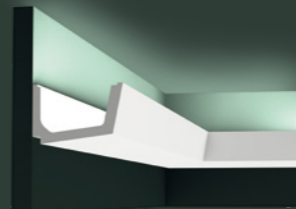

C357 STRAIGHT
200 x 7,1 x 11 cm
Purotouch®

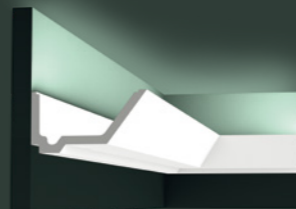
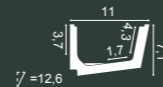

C358 RAIL
200 x 7,3 x 14 cm
Purotouch®

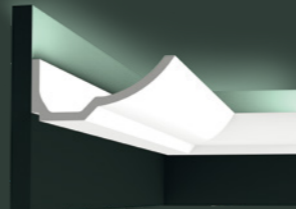
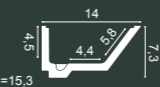

C351 BOAT
200 x 7,4 x 17,3 cm
Purotouch®

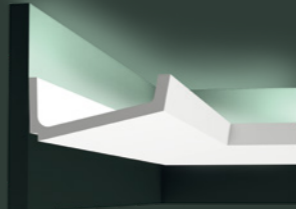
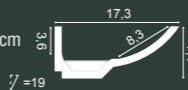

C352 FLAT
200 x 7,6 x 17,1 cm
Purotouch®

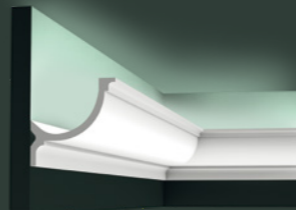

C902 | C902F
200 x 10,3 x 10,3 cm
Purotouch®

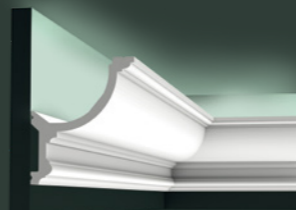

C901 | C901F
200 x 14,8 x 12,4 cm
Purotouch®

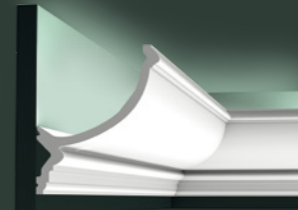

C900
200 x 17,1 x 14,6 cm
Purotouch®



79

Led Coving



C380 L3 Linear Led Lighting
200 x 5 x 5 cm
Purotouch®

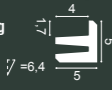

C381 L3 Linear Led Lighting
200 x 9,5 x 5 cm
Purotouch®

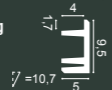

C382 L3 Linear Led Lighting
200 x 14 x 5 cm
Purotouch®



C383 L3 Linear Led Lighting
200 x 14 x 5 cm
Purotouch®



Steps

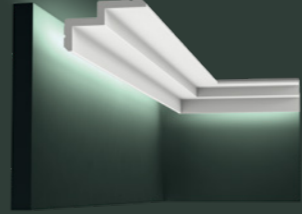

C390 STEPS
200 x 6 x 10 cm
Purotouch®

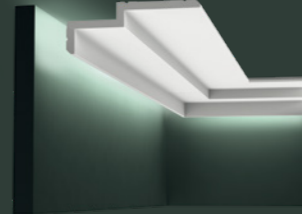
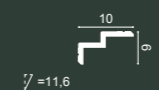

C391 STEPS
200 x 6 x 16 cm
Purotouch®

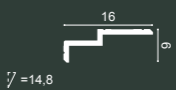

C394 STEPS
200 x 9,5 x 3,1 cm
Purotouch®

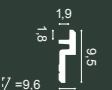

C395 STEPS
200 x 15,5 x 3,1 cm
Purotouch®

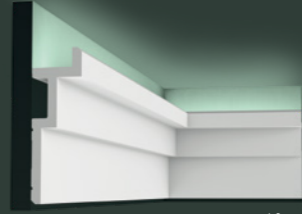

C396 STEPS
200 x 18,5 x 6,1 cm
Purotouch®

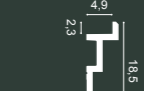

L3 Lighting Combinations

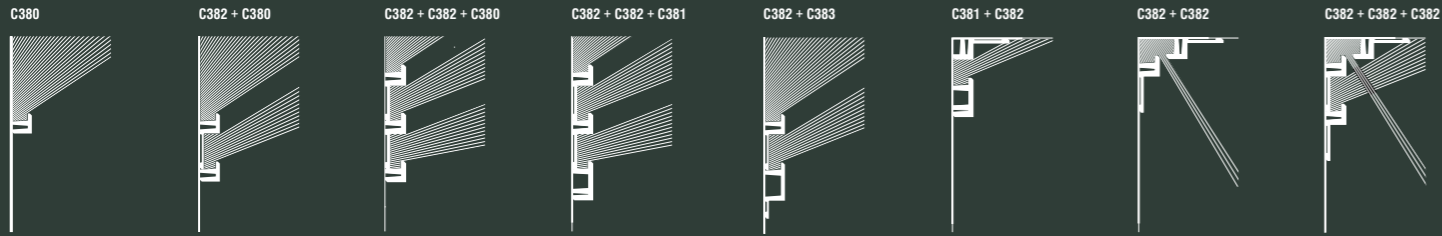
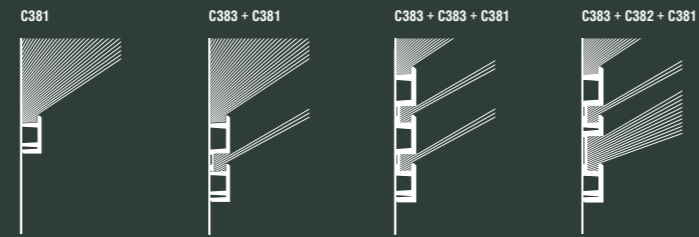



CX190 | CX190F U-PROFILE
200 x 2 x 3 cm
Duropolymer®

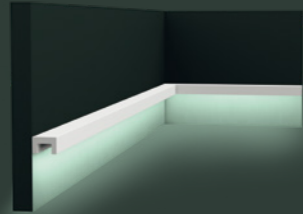

CX190 | CX190F U-PROFILE
200 x 2 x 3 cm
Duropolymer®

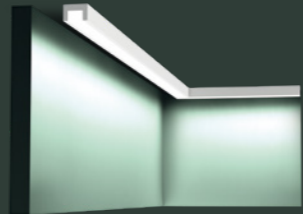

CX190 | CX190F U-PROFILE
200 x 2 x 3 cm
Duropolymer®



CX189 | CX189F
200 x 2,7 x 2,7 cm
Duropolymer®

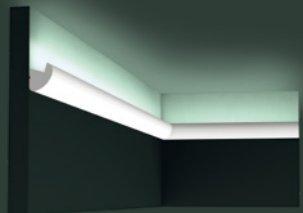

CX188 | CX188F
200 x 3,4 x 3 cm
Duropolymer®

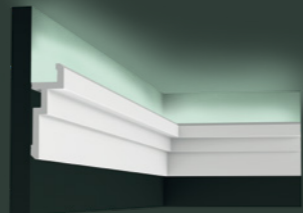

CX196 U-STEPS
200 x 11,3 x 4 cm
Duropolymer®

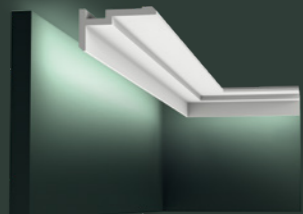

CX197 U-STEPS
200 x 5 x 9,3 cm
Duropolymer®

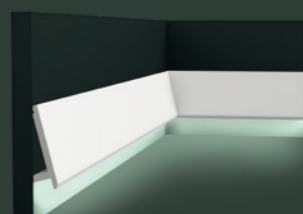

SX179 | SX179F DIAGONAL
200 x 9,7 x 2,9 cm
Duropolymer®

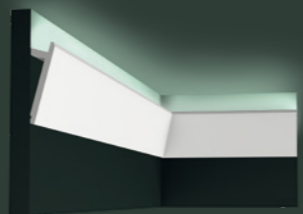

SX179 | SX179F DIAGONAL
200 x 9,7 x 2,9 cm
Duropolymer®

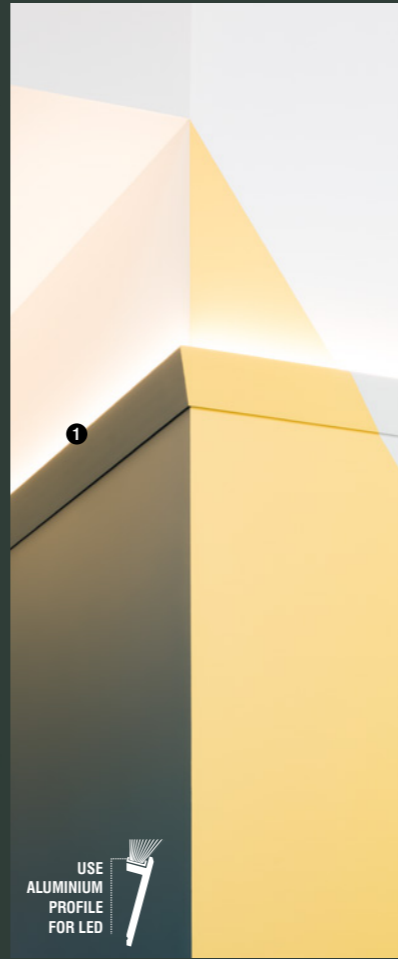

1. SX179 p.82

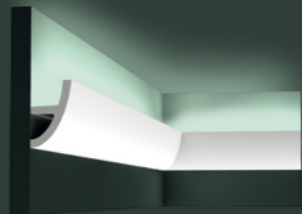

C373 | C373F ANTONIO
200 x 8 x 5 cm
Purotouch®

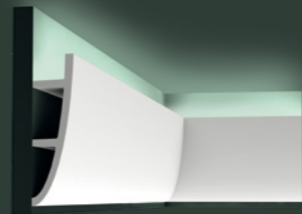

C374 | C374F ANTONIO
200 x 18 x 5 cm
Purotouch®

C373 + C374



C373 + C373

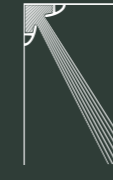

C374 + C991



C373 + C373

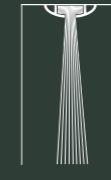

C374 + C374

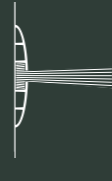

C373 + C374

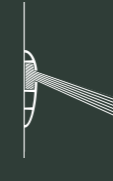

C373 + C373

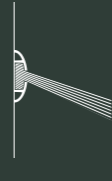

C374 + C373

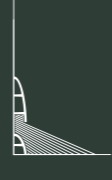

C373 + C374

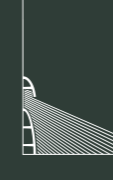

C374 + C374

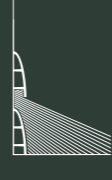

C373 + SX167

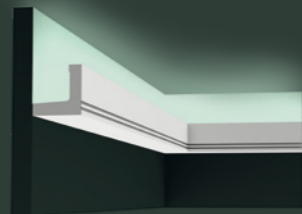
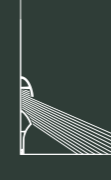

C361 STRIPE
200 x 5 x 5 cm
Purotouch®

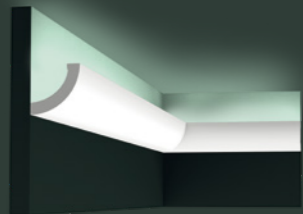

C362 CURVE
200 x 5 x 5 cm
Purotouch®

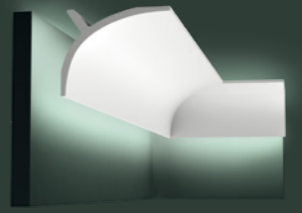

C991
200 x 11 x 14 cm
Purotouch®

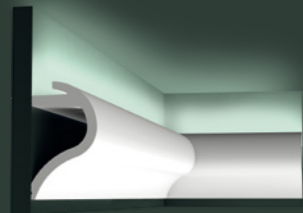

C364 WAVE
200 x 14 x 8 cm
Purotouch®

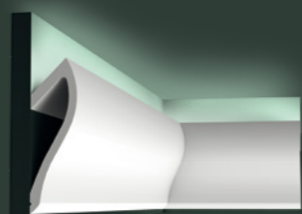

C371 SHADE
200 x 18,5 x 5,8 cm
Purotouch®

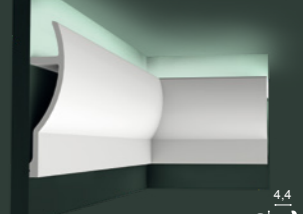

C372 FLUXUS
200 x 28 x 7 cm
Purotouch®

Deco Elements

DECORATIEVE ELEMENTEN
ELÉMENTS DÉCORATIFS
ZIERELEMENTE
ELEMENTOS DE DECORACIÓN
ELEMENTI DECORATIVI

CEILING ROSES / ROZETTEN / ROSACES / ROSETTEN / ROSETONES / ROSONI



R10 ⊕
ø 15 x 4,2 - ø 2 cm
Purotouch®



R11
ø 19 x 3,6 - ø 3 cm
Purotouch®



R12
ø 19,5 x 1,8 - ø 1 cm
Purotouch®



R13 ⊕
ø 28 x 3,1 - ø 2,5 cm
Purotouch®



R14 ⊕
ø 33 x 3 - ø 2,5 cm
Purotouch®



R31 ⊕
ø 38,5 x 2,7 - ø 3,5 cm
Purotouch®



R17 ⊕
ø 47 x 3,5 - ø 6,5 cm
Purotouch®



R18
ø 49 x 4,7 - ø 7 cm
Purotouch®



R52 ⊕
ø 69,5 x 4,8 - ø 12,5 cm
Purotouch®



R73 ⊕
ø 70 x 5,9 - ø 8 cm
Purotouch®



R23
ø 71 x 4,4 - ø 6 cm
Purotouch®



R27
ø 75 x 4,5 - ø 9 cm
Purotouch®

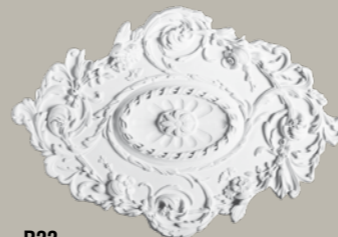

R22
77,5 x 53 x 3,6 cm
Purotouch®



R24
ø 79 x 6 - ø 8 cm
Purotouch®



R64 ⊕
ø 95,2 x 4,8 - ø 7 cm
Purotouch®



R07
ø 26 x 3 - ø 5 cm
Purotouch®



R08
ø 38 x 4,2 - ø 5 cm
Purotouch®



R09 +
ø 48,5 x 3,7 - ø 6 cm
Purotouch®



R66
ø 54,5 / 43 x 2,4 cm
Purotouch®



R76
ø 62 x 4,1 - ø 10,5 cm
Purotouch®



R77
ø 62 x 4,2 - ø 10,5 cm
Purotouch®



R40 +
ø 74,5 x 3,1 - ø 10 cm
Purotouch®

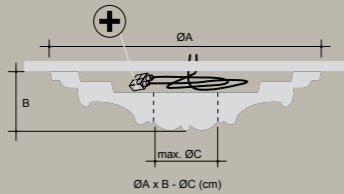

+ ROOM FOR CABLES
Holte voor kabels
Place pour les câbles
Hohlraum für Kabel
Espacio para cables
Spazio per i cavi



1. R52 p.85 | 2. R17 p.85 | 3. R31 p.85 | 4. R10 p.84

PEDIMENTS / FRONTONS / PEDIMENTE / FRONTALES / FRONTONI



D400
127,5 x 14,5 x 5,5 cm
Purotouch®



D401
127,5 x 14,5 x 5,5 cm
Purotouch®



D170
105 x 24,5 x 3,2 cm
Purotouch®



D402
15 x 12,1 x 5,8 cm
Purotouch®
(only for D400 and D401)

PANELLING / PANELEN / PANNEAUX / PANELE / PANELES / PANNELI PER PORTA

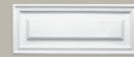

D504
55 x 22 x 1,7 cm
Duropolymer®



D506
43 x 43 x 1,7 cm
Duropolymer®



D503
55 x 55 x 1,7 cm
Duropolymer®



D507
55 x 90,5 x 1,7 cm
Duropolymer®



The Perfect Finish
PG. 92 - 93



DOOR FRAMES / DEUROMLIJSTINGEN / ENCADREMENTS DE PORTES
TÜRUMRANDUNGEN / MARCOS PARA PUERTAS / CONTORNI PORTA

D210

9,6 x 9,6 x 3,5 cm
Duropolymer®

DX121-2300

230 x 9,4 x 2,3 cm
Duropolymer®



D200

9,6 x 9,6 x 3 cm
Duropolymer®

DX119-2300

230 x 9,2 x 2,2 cm
Duropolymer®



2 DX170-2300

230 x 11,9 x 3,2 cm
Duropolymer®



DX174-2300

230 x 6 x 2,2 cm
Duropolymer®



**DX157-2300 |
DX157-2300 RAL 9003**

230 x 6,6 x 1,3 cm
Duropolymer®



**DX163-2300 |
DX163-2300 RAL 9003**

230 x 10,1 x 1,3 cm
Duropolymer®



D310

9,5 x 24,9 x 3,1 cm
Duropolymer®

D310

9,5 x 24,9 x 3,1 cm
Duropolymer®

1 D330LR (2pc)

12,6 x 16 x 4,1 cm
Duropolymer®

D340

7 x 11 x 2,5 cm
Duropolymer®



FULL COLUMNS / VOLLE ZUILEN / COLONNES ENTIÈRES
VOLLSÄULEN / COLUMNAS COMPLETAS / COLONNE INTERE

HALF COLUMNS / HALVE ZUILEN / DEMI-COLONNES
HALBSÄULEN / MEDIAS COLUMNAS / MEZZE COLONNE

PILASTERS / PILASTRES / PILASTER / PILASTRAS / PILASTRI

K1112
(H 30cm)
Duropolymer®



K1122
(H 30cm)
Duropolymer®



K1002
(H 199,5cm)
Purotouch®



K1102
(H 202cm)
Purotouch®



K1112 + K1002 + K1152 = 242 cm H
K1112 + K1002 + K1132 = 287 cm H max
K1122 + K1102 + K1152 = 242 cm H
K1122 + K1102 + K1132 = 287 cm H max

K1152 (H 12,5 cm)
Duropolymer®



K1132 (H 57,5 cm)
Purotouch®



K1111
(H 30cm)
Duropolymer®



K1121
(H 30cm)
Duropolymer®

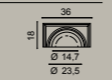

K1001
(H 199,5cm)
Purotouch®

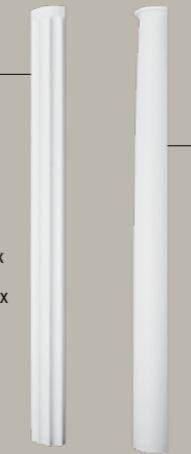
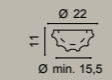

K1101
(H 202cm)
Purotouch®

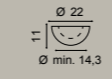

K1111 + K1001 + K1151 = 242 cm H
K1111 + K1001 + K1131 = 287 cm H max
K1121 + K1101 + K1151 = 242 cm H
K1121 + K1101 + K1131 = 287 cm H max

K1151
(H 12,5 cm)
Duropolymer®

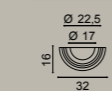

K1131
(H 57,5 cm)
Purotouch®

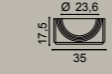

K251
(H 35 cm)
Purotouch®

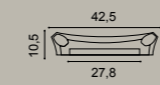

K250
(H 200 cm)
Purotouch®

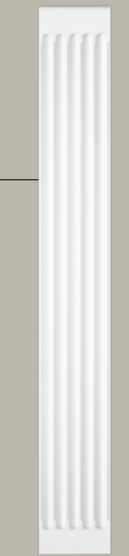
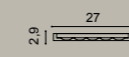

K201 (H 14,9 cm)
Purotouch®

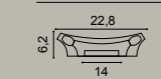

K200 (H 200 cm)
Purotouch®

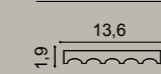

D320 (H 24,8 cm)
Purotouch®



K254 (H 53,5 cm)
Purotouch®

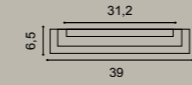

K202 (H 54,1 cm)
Purotouch®

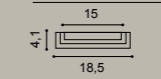

The Perfect Finish

De perfecte afwerking / La finition parfaite / Das perfekte Finish / El acabado perfecto / La finitura perfetta

Ready? Set? Go!



INSTALLATION
WARRANTY

ONLY FULL WARRANTY WITH DECOFIX

VOLLEDIGE GARANTIE ENKEL BIJ GEBRUIK VAN DECOFIX
GARANTIE TOTALE UNIQUEMENT AVEC COLLE DECOFIX
VOLLSTÄNDIGE GARANTIE NUR BEI DER VERWENDUNG VON DECOFIX
GARANTÍA COMPLETA SÓLO SI SE UTILIZA DECOFIX
GARANZIA COMPLETA SOLO CON COLLANTE DECOFIX

Ready?

SURFACE & ATMOSPHERE

Omgeving & Ondergrond | Environnement & Surface | Umgebung & Untergrund | Ambiente & Superficie | Ambiente & Superficie



Storage and installation conditions: Store profiles and adhesives at room temperature and wait 24 hours before installing.

Opslag- en plaatsingsvoorwaarden: Plaats profielen en lijmen 24 uur vóór de installatie op kamertemperatuur.
Conditions d'installation et de stockage: Stockez les profils et les colles à température ambiante 24 heures avant la pose.
Lager- und Installationsbedingungen: Profile und Kleber 24 Stunden vor Verlegung bei Zimmertemperatur lagern.
Condiciones de almacenamiento y de instalación: Colocar molduras y adhesivos en el lugar 24 horas antes de la aplicación.
Condizioni di installazione e stoccaggio: Tenere i profili e il collante a temperatura ambiente almeno 24 ore prima della posa.

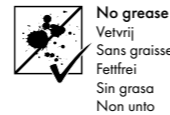
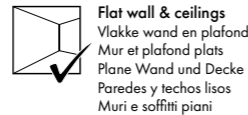
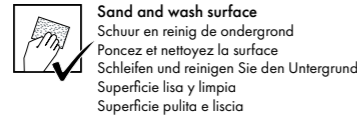
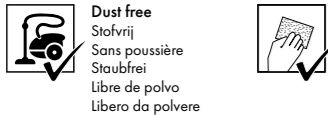

TOOLS | Toebehoren | Accessoires | Zubehör | Accesorios | Accessori

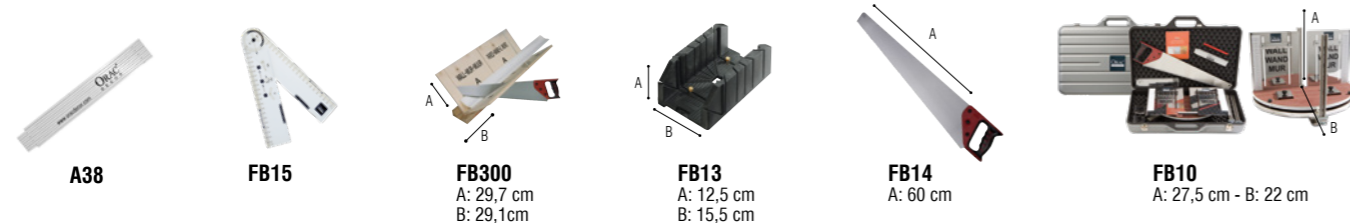

Set?

DECOFIX ADHESIVES

DecoFix lijmen | Colles DecoFix | DecoFix Kleber | DecoFix Adhesivos | Collanti DecoFix

Interior, porous and dry surface
Binnen, poreuze en droge ondergronden |
Pose à l'intérieur, surfaces poreuses, pièces non humides | Innen, poröse/saugfähige und trockene Untergründe | Interior, superficies porosas y secas | Per interni, superfici porose, ambienti asciutti

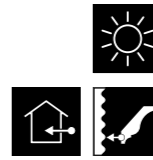

Exterior, non-porous and humid surface
Buiten, niet-poreuze en vochtige ondergronden |
Pose à l'extérieur, surfaces non poreuses, environnement humide | Außen, nicht-poröser/saugfähiger Untergrund und Feuchträume | Exterior, superficies no porosas, ambientes húmedos | Per esterno, superfici non porose, ambienti umidi



Seal wall/ceiling
Verbinding muur/plafond
Collage mur/plafond
Verbindung Wand/Decke
Adherencia techos/paredes
Incollaggio su muri e soffitti



DecoFix Pro

Strong, water-based acrylic installation adhesive

FDP500 310ml | 7 > 8m
FDP600 4200ml | 65 > 110m

or
of
ou
oder
o

DecoFix Power

Very strong MS-Polymer-based installation adhesive

FDP700 290ml | 7 > 8m



Joints between mouldings*
Verbinding tussen profielen
Joints entre les profils
Nahtverbindungen zwischen Profilen
Uniones de los perfiles
Unione delle giunte dei profili



DecoFix Extra
Polyurethane-based
adhesive

FX200 310ml | min. 80m
FX210 tube 80ml | min. 20m

*For Durofoam®: use DecoFix Pro for joints

Voor Durofoam®: gebruik DecoFix Pro voor de naden | Pour Durofoam®: utilisez DecoFix Pro pour les joints | Für Durofoam®: verwenden Sie DecoFix Pro für die Stoßstellen | Para Durofoam®: utilice DecoFix Pro para las uniones entre piezas | Per Durofoam®: usare DecoFix Pro per le giunte



Filler & finishing
Vullen en afwerking
Enduit et finition
Verfugen und Endbearbeitung
Relleno y acabado
Riempitivo e finitura



DecoFiller

Acrylic filler

FL300 310ml | > 30m

Go!



Installation Videos & Manuals
DecoFix Glue Calculator

SCAN THE QR CODE OR
VISIT WWW.ORACDECOR.COM > INSTALLATION

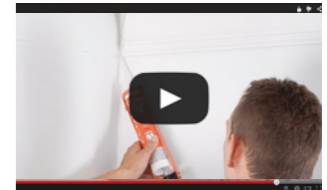

Flexible Products

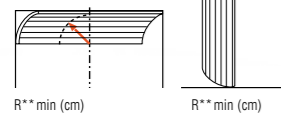
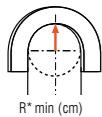
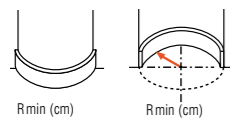

Flex Radius	R min in cm	R* min in cm	R** min in cm	Flex Radius	R min in cm	R* min in cm	R** min in cm	Flex Radius	R min in cm	R* min in cm	R** min in cm
C211F	250			CX132F	70			SX105F	30		
C213F	280			CX188F	110			SX118F	40		
C215F	160			CX189F	90			SX137F	40		
C217F	380			CX190F	30	130		SX138F	40		
C220F	400			CX199F	200			SX155F	30		
C230F	150			DX174F	60	300		SX157F	35	260	
C240F	270			P3020F	50	180		SX162F	20	80	
C250F	70			P4020F	40	200		SX163F	35		
C304F	250			P4025F	70			SX165F	40		
C321F	140			P5021F	20	70		SX172F	35		
C325F	300			P7070F	30	230		SX173F	45		
C326F	500			P8020F	40	130		SX180F	45		
C331F	420			P8030F	20	70		SX182F	35	100	
C333F	300			P8040F	30			SX183F	40		
C334F	380			P8050F	80	200		SX184F	45		
C339F	380			P9010F	40	310		SX187F	40		
C341F	400			P9050F	20	60		SX194F	25	80	
C373F	100			P9900F	20	250		SX195F	30		
C901F	600			PX103F	20	80		W108F	30		40
C902F	600			PX120F	30	110		W109F	30		40
CX100F	200			PX144F	20	220		W110F	30		40
CX106F	360			PX175F	30	80		W111F	30		40
CX109F	160			PX198F	70			W114F	30		40
CX110F	180			PX201F	30	80		W116F	30		40
CX123F	280			PX202F	60	150		W119F			40
CX124F	160			PX209F	20	70					
CX127F	240			SX104F	40						

94



en

A wide range of cornice mouldings, panel mouldings and skirting boards are available to give curved walls and ceilings an elegant finish. These elements are also light and can be painted.

The sky is the limit: add curved lines and circles to your walls and ceilings in no time.

fr

De nombreuses corniches, cimaises et plinthes sont disponibles dans des modèles variés. Les murs et plafonds courbes peuvent également bénéficier d'une finition élégante. En outre, ils sont clairs et peuvent être peints!

Vous n'auriez jamais imaginé qu'il serait aussi facile d'installer des lignes courbes et des cercles au mur et au plafond.

es

Hay disponible una variante flexible para una gran variedad de cornisas, molduras y zócalos. Así se puede dar un elegante acabado a paredes y techos arqueados. ¡Además, son ligeros y están listos para pintar!

Todo lo que te puedas imaginar: coloca líneas arqueadas y círculos sin problema en la pared y el techo.

nl

Een groot aantal kroonlijsten, wandlijsten en plinten zijn verkrijgbaar in een flexibele variant. Ook gebogen wanden en plafonds kunnen zo elegant worden afgewerkt. Ze zijn bovendien ook licht en overschilderbaar!

Je kan het zo gek niet bedenken: gebogen lijnen en cirkels zet je zonder enige moeite op muur en plafond.

de

Sehr viele Fries-, Wand- und Sockelleisten sind in flexibler Ausführung erhältlich. Auch geschwungene Wände und Decken lassen sich so elegant verschönern. Zudem sind sie leicht und können überstrichen werden!

Unvorstellbar! Auch geschwungene Linien und Kreise lassen sich problemlos an Wänden und Decken anbringen.

it

Una vasta gamma di cornici soffitto, cornici parete e battiscopa disponibili anche nella versione flessibile per decorare pareti e soffitti curvi in modo elegante. Anche questi elementi sono leggeri e possono essere verniciati.

Non avresti mai immaginato che sarebbe stato così facile decorare con linee curve e cerchi muro e soffitto.

Discover our flexible collection. | Ontdek onze flexibele collectie. | Découvrez notre collection flexible. | Entdecken Sie unsere flexible Kollektion. | Descubre nuestra colección flexible.

95

SPECIAL THANKS TO

Sur Mesure Interieur	www.surmesure-interieur.be	28, 63
dejaegerinterieurarchitecten	www.dejaegerinterieurarchitecten.be	21
Ligne Pure	www.lignepure.com	6
Heerenhuis Manufactuur	www.heerenhuis.be	6, 10-11
Ethnicraft	www.ethnicraft.com	6, 54
Authentic and so	www.authenticandso.com	10-11
PR Living	www.prliving.com	12-13
Limited Edition	www.le.be	12-13
Ton sur Ton	www.tonsurton.be	29, 75
Simon De Backere	www.simondebackere.be	29, 75
Joana Sultan_Agence Gabeli	www.agence-gabeli.fr	19
Atelier DAAA	www.atelierdaaa.com	27
Romain Ricard	www.romainricard.com	27
CASA DECOR Madrid	www.casadecor.es	24, 39, 68
Dica	www.dica.es	24
Frederiek Van Pamel	www.frederiekvanpamel.be	23

WeWantMore	www.wewantmore.studio	19
Boulangerie Henri	www.boulangerie-henri.be	17
Pillows Grand Boutique Hotel Reylof	www.pillowshotels.com/ghent	16
Balo	www.balo.be	40
Restaurant Du Progres	www.duprogres.be	44-45
Groep Versluys	www.groepversluys.be	32
Alexandra Chigintseva, Igor Gulytyaev	www.chigintseva.ru	56
Virginia Gasch	www.vglliving.com	68
Ekaterina Pozdnyakova	www.pozdnyakovadesign.ru	77
De Huiskamer	www.dehuiskamer.be	86
Syngedauw Nicolas	info@nsdeco.be	86
Bert Demasure	www.bertdemasure.com	24, 46, 89
Cafeine	www.cafeine.be	
Frederik Vercruysse	www.frederikvercrussse.com	1
Verne	www.verne.be	9
& Jill, Brecht-Alexander, Laura, Leon en Heloise		

96

REGISTERED CTM DESIGN N°

C323/006632071-0001	C355/000257464-0007	C395/005329026-0002	DX168-2300/002341727-0004	R70/2088880-0006	W105/004097780-0001
C324/006632071-0002	C356/000257464-0008	C396/005329026-0003	DX170/002524769-0008	SX156/000995576-0006	W106/005329026-0008
C325/006632071-0003	C361/1890526-0001	C990/000995576-0002	DX174-2300/003242569-0011	SX165/002341727-0001	W107/005329026-0009
C326/006632071-0004	C362/1890526-0002	C991/002524769-0007	CB500/1035273-0006	SX171/002920140-0001	W108/005329026-0010
C327/006632071-0005	C363/1890526-0003	CB501/1035273-0005	DX182/004097780-0002	SX172/003242569-0013	W109/006379848-0001
C335/000995576-0001	C364/1890526-0004	CB502/1035273-0007	DX183/004097780-0003	SX173/003242569-0014	W110/006379848-0002
C336/1035273-0001	C370/2088880-0001	CB503/1890526-0005	DX184/004097780-0004	SX179/003242569-0015	W111/008175871-0004
C338/1978214-0001	C371/2088880-0002	CB510/1035273-0004	P3020A/002341727-0005	SX180/003242569-0016	W112/008175871-0005
C338A/002341727-0007	C372/2088880-0003	CB511/1035273-0003	P3070/2088880-0004	SX181/003242569-0017	W113/008175871-0006
C338B/002341727-0006	C373/002524769-0005	CB512/1890526-0007	P3071/2088880-0005	SX185/004097780-0005	W114/008711071-0001
C339/1978214-0002	C374/002524769-0006	CB523/1035273-0002	P4025/006632071-0007	SX186/004097780-0006	W116/008711071-0002
C340/1978214-0003	C380/003242569-0001	CB530/1890526-0008	P8050/000995576-0003	SX187/005329026-0007	W120/006632071-0009
C341/002524769-0001	C381/003242569-0002	CB531/1890526-0009	P8060/1810706-0002	SX191/006632071-0008	W121/006632071-0010
C342/002524769-0002	C382/003242569-0003	CX176/003242569-0009	P9900/000995576-0004	SX193/008175871-0001	W122/006632071-0011
C343/002524769-0003	C383/003242569-0004	CX177/003242569-0010	P9901/000995576-0005	SX194/008175871-0002	W123/006632071-0012
C344/002524769-0004	C390/003242569-0005	CX188/005329026-0004	PB513/1890526-0006	SX195/008175871-0003	W130/006987111-0001
C351/000257464-0003	C391/003242569-0006	CX189/005329026-0005	PX147/002341727-0003	W100/003356278-0001	
C352/000257464-0004	C392/003242569-0007	CX190/005329026-0006	PX169/002341727-0002	W101/003356278-0002	
C353/000257464-0005	C393/003242569-0008	CX192/006632071-0006	PX175/003242569-0012	W102/003356278-0003	
C354/000257464-0006	C394/005329026-0001			W103/003356278-0004	

Guarantee terms and conditions apply if provided installation instructions have been followed to the letter. Fire retardant standards. In many interiors and projects strict fire regulations are imposed. Therefore, ORAC has implemented a number of solutions depending on the country and its regulations. Please contact us for more information. The information in this catalogue is without engagement. Changes and discrepancies in sizes or/and shapes against those stated in the catalogue can occur. This catalogue and the design embodied within are protected by copyright law and international treaties. Unauthorized reproduction of the catalogue, any portion of it or the reproduction of the designs embodied therein may result in severe civil and criminal penalties and will be prosecuted to the maximum.

Further legal information can be found on: www.oracdecor.com/nl/disclaimer.

GIVE WALLS *PERSONALITY*

ORAC HEADQUARTERS

NV ORAC SA

Biekorfstraat 32
8400 Ostend, Belgium
T +32 59 80 32 52
info@oracdecor.com

ORAC BENELUX

Biekorfstraat 32
8400 Ostend, Belgium
NL: T +31 852 08 40 59
BeLux: T +32 59 79 02 82
benelux@oracdecor.com

ORAC DEUTSCHLAND

Boltensternstraße 159A
50735 Köln, Germany
T +49 221 747 499 39
deutschland@oracdecor.com

ORAC AUSTRIA

T +43 662 23 49 27
oesterreich@oracdecor.com

ORAC FRANCE

13 Rue Séguier
75006 Paris, France
T +33 188803631
france@oracdecor.com

ORAC EXPORT

T +32 59 79 02 83
export@oracdecor.com

ORAC SLOVAKIA S.R.O.

Kpt. Nalepku 6
08271 Lipany - SK
T +421 232 784 952
slovakia@oracdecor.com

ORAC SPAIN

C/ Roger de Llúria 67-69 Pral 2ª
08009 Barcelona - ES
T +34 938 56 49 00
spain@oracdecor.com

ORAC (UK) LTD

Office: Unit 8, City Bus. Ctr.
6 Brighton Rd, Horsham RH13 5BB - UK
T +44 1403 240 102
uk@oracdecor.com

ORAC IRELAND

T +35 381 8000 280
ireland@oracdecor.com

ORAC ITALIA SRL

Corso Giacomo Matteotti, 5/H
23900 Lecco (LC), Italy
T +39 0341 362062
italia@oracdecor.com